

# CALLERLAB

## BASIC CHALLENGE

### (C-1)

## DEFINITIONS

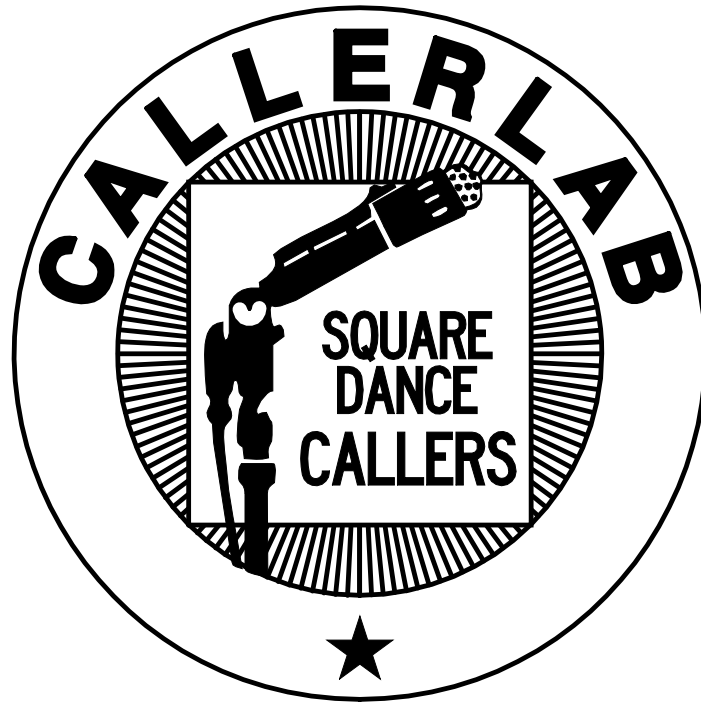

March 14, 2026

© Copyright 1983, 1986-1988, 1995-2026 Bill Davis, John Sybalsky, and CALLERLAB Inc., The International Association of Square Dance Callers. Permission to reprint, republish, and create derivative works without royalty is hereby granted, provided this notice appears. Publication on the Internet of derivative works without royalty is hereby granted provided this notice appears. Permission to quote parts or all of this document without royalty is hereby granted, provided this notice is included. Information contained herein shall not be changed nor revised in any derivation or publication.

## Table of Contents

Read this First.....	1	Jaywalk.....	30
Regional Styling Differences.....	1	Linear Action.....	30
General Rules.....	1	Magic Column Formation / Concept.....	30
How We Name Dancers.....	2	Make Magic.....	32
Starting Formations.....	4	O Concept.....	32
Glossary of Descriptive Terms Used at C-1.....	5	Pass the Axle / The Axle.....	32
Glossary of Modifying Terms.....	6	(Pass) The Axle (but) Cast (Off) N/4.....	32
Calls with Parts.....	8	(Pass) The Axle But <anything>.....	32
Calls with a Clear First and/or Last Part.....	10	Percolate.....	32
When the Formation Isn't There.....	11	Percolate But <anything>.....	32
How Calls Are Extended at C-1.....	13	Phantom Formation / Concept.....	33
C-1 Definitions.....	15	Press Ahead.....	33
Ah So.....	15	Recycle variations.....	34
Alter the Wave.....	15	All 8 Recycle.....	34
Block Formation.....	16	2/3 Recycle.....	34
<main call> But <anything>.....	16	Split / Box Recycle.....	34
Butterfly and O Concepts.....	17	Regroup.....	35
Cast Back / Cross Cast Back.....	20	Relay the Shadow.....	35
Chain Reaction.....	21	Relay the Top.....	35
Chase Your Neighbor.....	21	Reverse Explode.....	35
Chase Your Cross Neighbor.....	21	Rotary Spin.....	35
Checkover.....	22	Rotate Family.....	36
Circle By <m> and <n>.....	22	Rotate / Reverse Rotate.....	36
Concentric Concept.....	22	Single Rotate / Reverse Single Rotate.....	37
Counter Rotate.....	25	Scatter Scoot / Scatter Scoot Chain Thru.....	37
Cross and Turn / Reverse Cross and Turn.....	26	Scoot and Little / Little.....	37
Cross By.....	26	Scoot and Plenty / Plenty.....	38
Cross Chain Thru / Cross Chain and Roll.....	26	Scoot and Ramble / Ramble.....	40
Cross Extend.....	27	Shakedown.....	40
Cross Roll to a Wave / Line.....	27	Siamese Concept.....	40
Cross Your Neighbor.....	28	Spin the Windmill variation.....	40
Pass and Roll Your Cross Neighbor.....	28	<anything> the Windmill.....	40
Diamond Chain Thru variation.....	28	Split Square Thru variations.....	40
<anything> Chain Thru.....	28	Split Square Chain the Top.....	41
Dixie Diamond.....	28	Split Dixie Style to a Wave.....	41
Dixie Sashay.....	28	Split Dixie Diamond.....	41
Flip the Line (1/4, 1/2, 3/4, Full).....	28	Split Dixie Sashay.....	41
Follow Thru.....	28	Square Chain the Top.....	41
Galaxy Formation / Circulate / Cut / Flip.....	29	Square the Bases.....	41
Interlocked Diamond Formation.....	29	Square the Bases But <anything>.....	41
Interlocked Diamond Circulate.....	29	Squeeze Family.....	42
Cut the Interlocked Diamond.....	29	Squeeze.....	42
Flip the Interlocked Diamond.....	30	Squeeze the Galaxy / Hourglass.....	42
		Squeeze the Butterfly / O.....	42
		Squeeze the Diamond.....	43
		Step and Flip.....	43

Step and Fold.....	44
Step and Squeeze.....	44
Stretch Concept .....	45
Substitute .....	46
Swing and Circle (1/4, 1/2, 3/4, Full) .....	46
Swing the Fractions.....	47
Switch the Line.....	48
Switch to an Interlocked Diamond.....	48
T-Bone Formation.....	48
<Tag> Back Family .....	50
Flip Back .....	50
Tag Back .....	50
Vertical Tag Back .....	50
Tally Ho .....	51
Tandem Concept .....	51
3 by 2 Acey Deucey .....	52
Track (0, 1, 2, 3, 4).....	52
Triangle Formation / Triangle Circulate.....	52
Inside / Outside Triangles .....	53
Inpoint / Outpoint Triangles.....	53
Tandem-Based / Wave-Based Triangles.....	53
Triple Box / Column / Line / Wave Concept ...	54
Twist the Line / Twist and <anything>.....	55
Vertical Tag (1/4, 1/2, 3/4, Full).....	56
<anything> to a Wave .....	57
Weave.....	57
Wheel and <anything> .....	57
Reverse Wheel and <anything>.....	58
Wheel Fan Thru.....	58
With the Flow .....	58
Zing .....	59
History of Document Changes.....	60

## Read this First

This set of definitions is an attempt to capture the real meaning for each call on the C-1 list. It is intended to serve as the referee for disputes about exactly what a call means, and as a basis for teaching the calls properly.

Whenever the “technical” definition of a call is too long or complicated to do a “first teach” from, we have provided a teaching definition or teaching hints. This way, the definitions can meet both sets of needs. Naturally, dancers should be introduced to the full definition of each call as soon as your judgment dictates.

Before you use these definitions, you should be familiar with the latest versions of the CALLERLAB Basic, Mainstream, Plus, and Advanced definitions and the standard formation names. These documents can be downloaded from the CALLERLAB website at

<https://www.callerlab.org/dance-programs/>

Where possible, we have used calls and formations defined in those documents. This has let us make the definitions shorter and clearer.

## Regional Styling Differences

CALLERLAB recommends that calls such as Swing Thru and Spin the Top be danced using the hands-up position and the palm star handhold. Many areas of the square dance world continue to use forearm turns for all turning actions. In order to eliminate the controversy over the use of forearm turns, the CALLERLAB membership approved a 1992 resolution recognizing that regional differences in styling exist.

## General Rules

All of the general rules which apply to the Basic, Mainstream, Plus, and Advanced definitions also apply at C-1.

**Facing Dancers:** Facing Dancers, unless otherwise specified, may be any combination of Boys and Girls.

**Couples:** Couples, unless otherwise specified, may be any combination of Boys and Girls.

**Facing Couples Rule:** Some calls that normally start from an Ocean Wave can also be done from Facing Couples. In that case, the dancers first step into a momentary Right-Hand Ocean Wave and complete the call—unless the caller specifically directs a left-hand call (for example, “Left Swing Thru”), in which case the dancers step into a momentary Left-Hand Ocean Wave and complete the call. This rule may also apply when calls that require Parallel Waves are called with the dancers in an Eight Chain Thru formation.

The Facing Couples Rule applies only to the C-1 calls Alter the Wave, Relay the Shadow, Relay the Top, and Swing and Circle.

**Ocean Wave Rule:** Some calls that normally start from Facing Couples can be done from a Wave. In that case, the dancers have already stepped forward toward each other and are ready to complete the remaining action of the call. This rule also applies when calls that start from two Facing Dancers (such as, Turn Thru) are called from a Mini-Wave.

The Ocean Wave Rule applies only to these C-1 calls (the Wave(s) must be right-handed): Cross Chain Thru, Cross Chain and Roll, Pass and Roll Your Cross Neighbor, Pass the Axle, The Axle (from a 3/4 Tag), Rotary Spin, Split Square Chain the Top, Split Dixie Style to a Wave, Split Dixie Diamond, Split Dixie Sashay, Square Chain the Top, and Square the Bases (from a Tidal Wave).

**Right-Shoulder Rule:** Whenever two dancers are moving toward each other and would otherwise collide, they pass right shoulders instead. If two dancers facing opposite directions must occupy the same spot on the floor at the same time, they step to form a Right-Hand Mini-Wave instead. You may not have two dancers who are facing the same direction, or at right angles, try to occupy the same spot.

## How We Name Dancers

For purposes of the definitions, we often have to identify specific dancers—say, the Ends of a Wave. There are a lot of ways to name people, and we use the ones that are common at C-1. For reference, we've listed them here:

**#1, #2, #3, #4:** The dancers in a Column are sometimes identified by number. The Very Lead dancer is called #1; the one behind #1 is #2, and so on. For example, here's how the dancers below would be named:

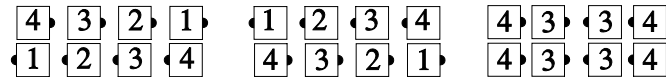

**Partner:** The dancer beside you in the smallest relevant two-dancer formation you are in. This means that, in each of the diagrams below, the dancer labeled 1 is dancer 2's partner.

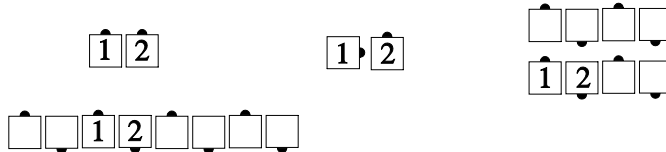

If the Centers are working together, they ignore the Outsides—but if everyone is active, the Centers may well have to work with the Outsides. For example, from Facing Lines, compare “Centers Pass Thru and Partner Tag” with “Centers Pass Thru and Everyone Partner Tag”:

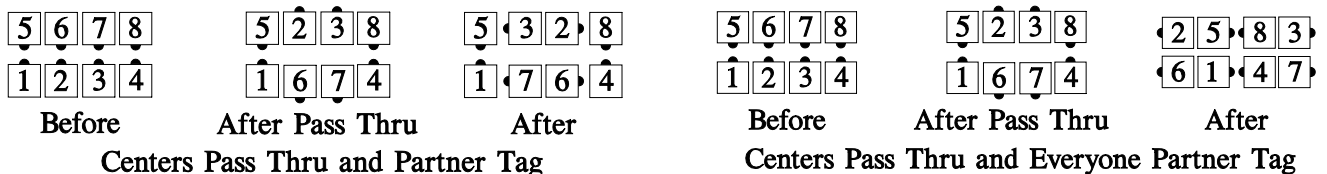

**Points and Centers:** In Diamonds and Hourglasses, there are Points and Centers. The Points in the diagrams below are marked “P” and the Centers are marked “C”:



**Box, Wave, and Diamond Dancers:** In Parallel Diamonds, Hourglasses, and Galaxies, you can identify dancers by what part of the formation they are in. In Parallel Diamonds there is a Wave inside a Box of dancers; in an Hourglass there is a Diamond inside a Box; in a Galaxy there is a Box inside a Diamond. In the diagrams below, Wave dancers are marked “W”, Diamond dancers are marked “D”, and Box dancers are marked “B”:

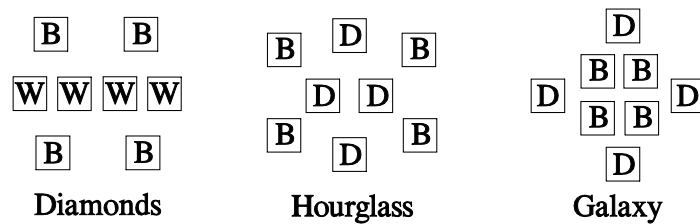

**Centers and Ends:** All four-dancer Line-like and Column-like formations have Ends and Centers. The dancers who are nearest the center of the formation are Centers, and the others are Ends—regardless of their facing direction. In the diagram below, the Centers are marked “C” and the Ends are marked “E”.



**Adjacent:** Two dancers are said to be "adjacent" if they are close to each other, with no intervening space or other dancers. This is true regardless of the dancers' facing directions. In the Diamond and Hourglass diagrams below, the dancers marked “A” are all adjacent to each other; the others aren't adjacent to anyone. In the Box diagram, dancers “B” and “C” are both adjacent to dancer “A”, but not to each other.

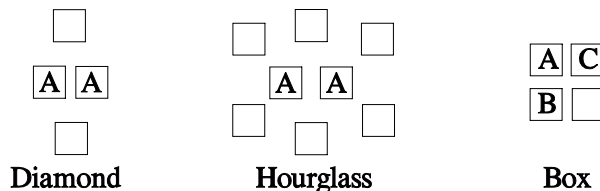

**Leads (or Leaders) and Trailers:** In any 1×2 formation (for example, Facing Dancers, a Tandem, Dancers Back-to-Back), those facing out of the 1×2 formation are called Leaders, and those facing into the 1×2 formation are called Trailers. A dancer who has one shoulder directly toward the center of the 1×2 formation is neither. In the pictures below, the dancers marked “L” are Leaders, and the dancers marked “T” are Trailers. Those not marked are neither.

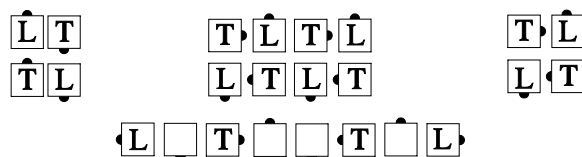

**Centers and Outsides:** Those dancers who are close to the center of the formation are Centers; the others are Outsides. In Lines and Columns, “End” and “Outside” are the same; in the other formations below, the Centers are marked with “C” and the Outsides with “O”.

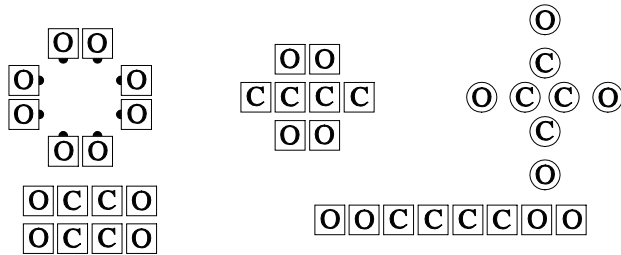

**Very Centers:** The two dancers closest to the flagpole center of the set are called the Very Centers or the Very Center Two. This term is only used when exactly two people are closest to the center. They are marked with “V” in the pictures below:

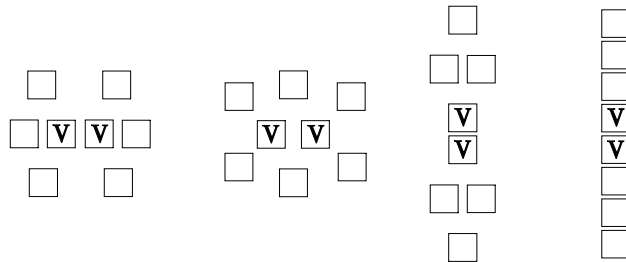

## Starting Formations

Each call's definition includes a list of possible starting formations for that call. Since it isn't practical to list every formation a call can start from, we do not mean to restrict you to the listed formations. However, this isn't a license to shoehorn a definition into an odd-ball formation.

Following the guidelines below will lead you to other legitimate starting formations; anything else should be avoided.

- The formations listed are usually the smallest from which the call can be done. Larger formations may be made of these smaller “units”. For example, “Switch to a Diamond” is defined to start from a single Wave, so it can also be done from Parallel Waves [ending in Parallel Diamonds], or from a Tidal Wave [ending in Point-to-Point Diamonds].
- Where they apply, you can use the general rules (Facing Couples, Ocean Wave) to find other starting formations. For instance, Pass and Roll can start from a Right-Hand Box Circulate formation even though that formation doesn't appear in the definition's list: The Ocean Wave Rule applies.
- If the word “only” appears in the list, then only the formations listed may be used. You may not apply the Facing Couples or Ocean Wave Rules. One call like this is Recycle—the Facing-Couples definition is not applicable from an Ocean Wave.

- If the way you plan to use a call requires that two conflicting rules apply, your usage is improper. For example, using the call “Cast a Shadow” from Lines Back-to-Back causes a conflict for the Ends: They are both Leaders, and each must meet the other with the outside hand. At the same time, the right-shoulder rule applies. Because of this conflict, that use of Cast a Shadow is improper.
- If the formation you give the call from can be broken into two different starting formations for the call, you have to specify which you mean. For example, the call “Dixie Style to a Wave” can start either from Facing Couples or from Facing Tandems. If it is called when the dancers are in a Double Pass Thru formation, they do not know which formation to start the call from—it could be broken down either way. In cases like this, you must tell the dancers which you want: either “Centers Dixie Style to a Wave” or “On a double track, Dixie Style to a Wave”.

## Glossary of Descriptive Terms Used at C-1

This section describes common C-1 applications of a few terms and calls first introduced in the Basic and Mainstream Programs.

**Face In:** Means “turn 1/4 in place, turning toward the center of the set”.

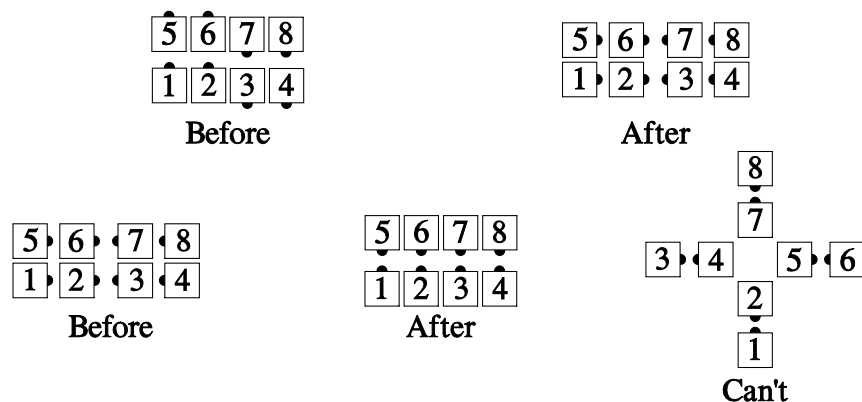

**Face Out:** Means “turn 1/4 in place, turning away from the center of the set”.

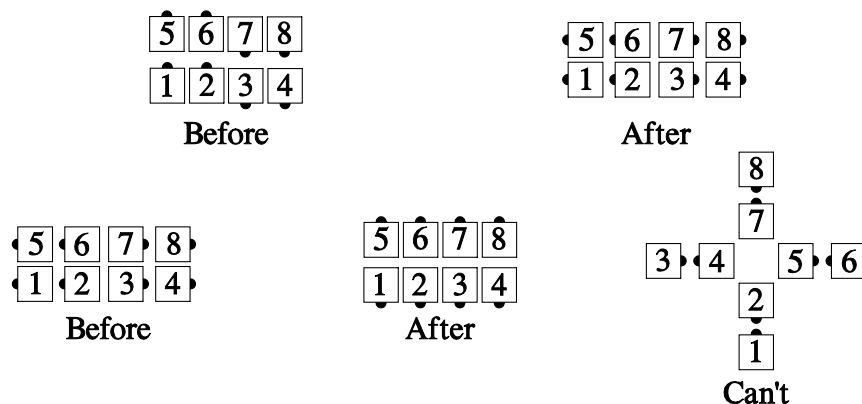

**Left Pass Thru:** This is the same as the Basic call Pass Thru, except the dancers pass left shoulders.

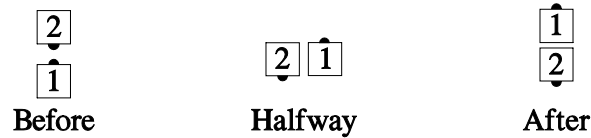

**Touch:** Facing Dancers step forward to join right hands—making a Right-Hand Mini-Wave.

**Left Touch:** Facing Dancers step forward to join left hands—making a Left-Hand Mini-Wave.



**Touch 1/2, 3/4:** Fractions other than 1/4 are allowed with Touch. For example, the call “Touch 1/2” is the same as “Touch and Trade”. In the same way, “Touch 3/4” is “Touch and Cast Off 3/4”.

**Cast Off 1/4, 1/2:** Fractions other than 3/4 are allowed with Cast Off. The rule is the same as for Cast Off 3/4, but the dancers move 1/4 or 1/2 instead of going the full 3/4.

## Glossary of Modifying Terms

The following terms can be used to modify the action of many calls. While not of the same stature as Concepts, these modifying terms have evolved from common English usage to have the following meaning and usage in the Challenge Program.

**Start:** The designated dancers do the first part of the call; they and everyone else do the rest of the call. Examples: From an Inverted Box, “Those Facing Start, Right and Left Thru”; from an Inverted Box with Boys as Trailers, “Boys Start, Pass the Ocean”; from Inverted Lines with Ends facing, “Ends Start, Load the Boat”; from certain T-Bone Boxes, “Girls Start, Touch a Quarter and Cross”.

**Finish:** Do all but the first part of the call. Examples: “Finish a Motivate”, “Finish a Rotary Spin”, “Finish a Pass and Roll”.

**Replace:** Dancers can be asked to replace (or substitute) one or more parts of the call (including the remainder of the call) with a different dance action. The part to be replaced can be described by its part number (for example, “the third part”) or by its dance action (for example, “the Stars”, “the Centers Trade”). Examples: “Scoot and Plenty, Replace the Split Circulates with a Motivate”, “Swing the Fractions, Replace the third part with a Split Circulate”, “Scoot and Plenty, Replace the Box Circulates with an Explode the Wave and do not finish the Plenty”.

**Ignore #1:** Can be used to ask the dancers to use all the spots in the formation, but to have designated dancers not move while the others do the call. Example: “Ignore the Head Boys, all Motivate”.

**Ignore #2:** Can be used as an aid in identifying formations. Example: From Point-to-Point Diamonds, “Ignore the Head Boys, Wave-Based Triangle Circulate”. From Two-Faced Lines, “Ignore the Lead End, Lines of 3, Out Roll Circulate”.

**Ignore #3:** Has been used to ask that one or more dancers and their spots be eliminated while the others do the call. This is considered incorrect usage. Example: From Two-Faced Lines, “Ignore the Trailing Centers, In Roll Circulate”.

**Interrupt:** The dance action of the call will temporarily be suspended at one or more places, at which point the specified action will be performed. The place can be described by its part (for example, “after the third part”) or by its definition (for example, “before turning the Stars”). Example: “Square Chain Thru, Interrupt before the last part with a Spin the Top”.

**Skip:** A shorthand for “Replace with Nothing”. Example: “Pass the Axle, Skip the third part”.

**Delete:** Another shorthand for “Replace with Nothing”. Example: “Delete all Arm Turn 1/2's and Spin Chain the Gears”.

**Special note for Replace, Interrupt, Skip, and Delete:** All of these modifiers may change each dancer's position in the formation or even change the formation itself. When the dancers resume their execution of the call, they must reevaluate their position in the formation and their new part in the definition. Examples: “Square Chain Thru, Interrupt before the last part with a Spin the Top” and “Swing the Fractions, Interrupt after each part with a Circulate”.

**Prefer:** Used to designate a dancer or dancers different from those specified in the definition. Two common uses are: from General Lines with Boys facing on the ends, “Prefer the Head Boys, In Roll Circulate”. From a General Line with the Boys and at least one Girl facing the same way, “Prefer the Boys, Explode the Line” (that is, the Boys step forward and all Face and Pull By).

**Left and Reverse:** In Challenge dancing, the Left or Reverse versions of the calls are part of the program even if they are not explicitly listed. (See the *CALLERLAB Advanced Definitions* for the discussion of the “Left” and “Reverse” modifiers.)



Mix 2 parts  
Centers Cross Run; Centers Trade.

Motivate 4 parts  
Circulate; Centers Cast Off 3/4 and Ends 1/2 Circulate;  
Center (Diamond) Star 1/2 as Others Trade;  
Those who meet Cast Off 3/4 as others Phantom Hourglass Circulate.

Pass and Roll 4 parts  
Pass Thru; Centers Turn Thru as Ends Right-Face U-Turn Back; Pass Thru;  
Centers Pass Thru as the Outsides do a Right Roll to a Wave to meet the Centers.

Pass In / Out 2 parts  
Pass Thru; Face In / Out.

Pass the Ocean 3 parts  
Pass Thru; Quarter In; Touch.

Pass the Sea 3 parts  
Pass Thru; Quarter In; Left Touch.

Pass to the Center 2 parts  
Pass Thru; Outsides Trade.

Peel the Top 2 parts  
Half Zoom; Fan the Top.

Quarter Thru / Three-Quarter Thru 2 parts  
Those who can Right Turn 1/4 (or 3/4); those who can Left Turn 1/2.

Recycle (as Extended at C-1) 3 parts  
Centers Fold and all adjust to a Box; Box Counter Rotate (1/4); Roll.

Remake (and Grand Remake) 3 parts  
Those who can Right Turn 1/4; those who can Left Turn 1/2;  
those who can Right Turn 3/4.

Remake the Thar 3 parts  
End and Adjacent Center Turn 1/4; alternating hands Turn 1/2; alternating hands Turn 3/4.

Right and Left Thru 2 parts  
Right Pull By; Courtesy Turn.

Scout Chain Thru (from a 1/4 Tag) 5 parts  
Extend; Swing; Slip; Swing; Extend.

Slide Thru 2 parts  
Pass Thru; Boys Face Right as Girls Face Left.  
(Note: In spite of the fact that the Slide Thru definition says “in a single smooth motion”,  
Challenge callers recognize two parts. A sample use is “Finish Slide Thru”.)

- Spin Chain Thru 4 parts  
End and Adjacent Center Turn 1/2; Centers Cast Off 3/4; Very Centers Trade;  
Centers Cast Off 3/4.
- Spin the Top 2 parts  
End and Adjacent Center Turn 1/2; Fan the Top.
- Spin the Windmill Centers have 3 parts  
Centers: Swing; Slip; Cast Off 3/4.
- Swing and Mix 3 parts  
End and Adjacent Center Turn 1/2; Centers Cross Run; Centers Trade .
- Swing Thru (or Left Swing Thru) 2 parts  
Within a group of three or four:  
Right Swing Thru: Those who can Right Turn 1/2; those who can Left Turn 1/2.  
Left Swing Thru: Those who can Left Turn 1/2; those who can Right Turn 1/2.
- Triple Star Thru 3 parts  
Those who can Star Thru; those who can do the mirror image of a Star Thru;  
those who can Star Thru.

## **Calls with a Clear First and/or Last Part**

The following list contains a few additional calls from other programs that do not fit in the previous list, but do have well-defined first and/or last parts.

- Linear Cycle  
The first part is “Ends and Adjacent Center Hinge”.  
(Although Linear Cycle is defined to have 3 parts, the second and third parts blend together. It is recommended that callers avoid trying to separate the last two parts.)
- Pass and Roll Your Neighbor  
The first part is “Pass Thru”.
- Relay the Deucey  
The first part is “End and Adjacent Center Turn 1/2”.  
The last part for the Centers is “Turn 3/4”.
- Spin Chain and Exchange the Gears  
The first part is “End and Adjacent Center Turn 1/2”.
- Spin Chain the Gears  
The first part is “End and Adjacent Center Turn 1/2”.  
The last part for the Centers is “Turn 3/4”.

## When the Formation Isn't There

In a number of places, the definitions call for certain dancers to do “their part of” some call even when the formation they are working in exists only in the mind's eye. For example, in the call “Switch to a Diamond”, the Ends of the Wave Diamond Circulate even though there is no Diamond. Similarly, in “Flip the Hourglass”, the Points Run as though they were in Parallel Lines. The cases used in the definitions are shown below. In each diagram, the corresponding positions in the corresponding formations are labeled alike. Unlabeled dancers have no corresponding places.

The Ends of Parallel Lines or Waves may act like the Points of an Hourglass. Similarly, the Points of an Hourglass may act as though they were the Ends of Parallel Lines:

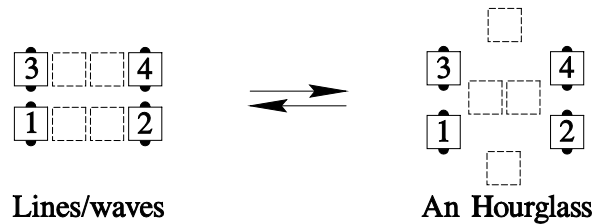

The Points of a Diamond may act like the Ends of a Line, or vice versa. The Centers of a Diamond may act like the Centers of a Line, or vice versa:

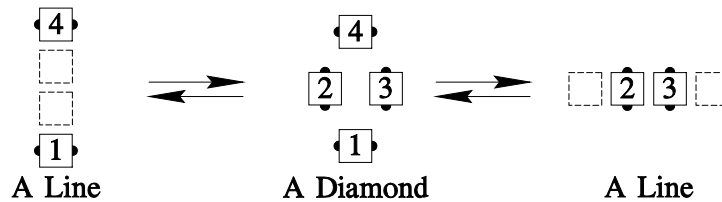

More generally, Outsides are said to be “Ends of (General) Lines” if they are in a Box consisting of two General Tandems that are “breathed apart,” either with Centers between them or on Squared Set Spots. In each of the following diagrams, dancers labeled with numbers are considered to be Ends of Lines.



Because of square breathing, Ends of Lines may be closer together or farther apart than Ends of actual Lines of Four would be, depending on how Center dancers are positioned. The Points of Twin Diamonds are considered to form Tandems even though the two dancers in each Tandem are farther apart than usual.

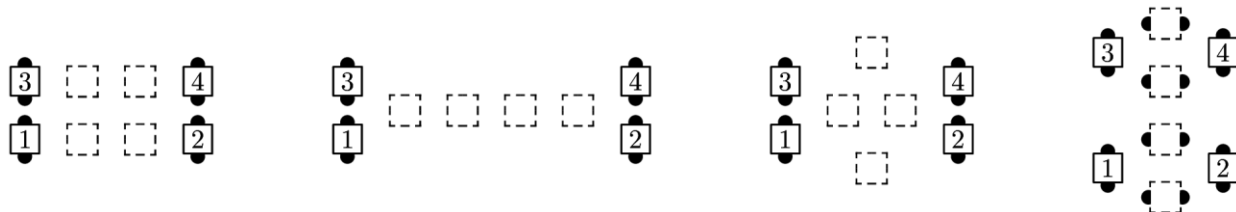

In the same way, Outsides are said to be “Ends of (General) Columns” if they are in a Box consisting of two General Couples that are “breathed apart.” In each of the following diagrams, dancers labeled with numbers are considered to be Ends of Columns.



Because of square breathing, Ends of Columns may be closer together or farther apart than Ends of actual Columns of Four would be, depending on how the center dancers are positioned.

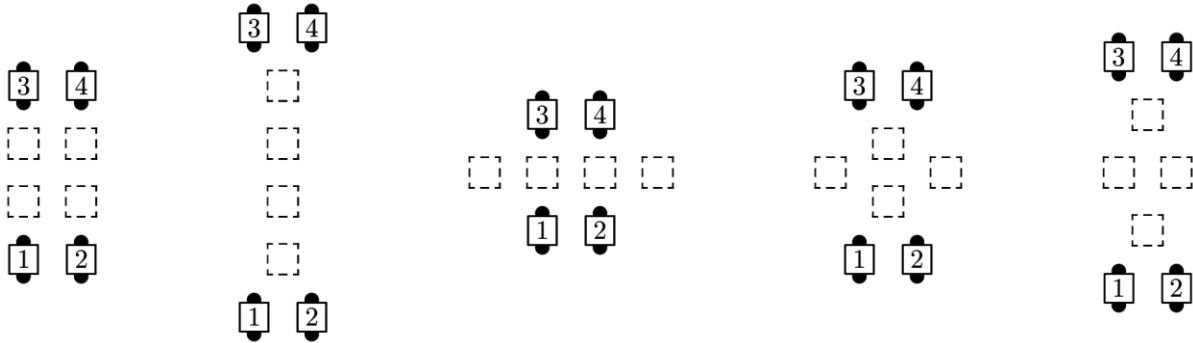

It may be that Outsides are T-Boned. In the following diagram, dancers 1 and 4 are Ends of Lines, and dancers 2 and 3 are Ends of Columns.



If dancers in any formation are either Ends of Lines or Ends of Columns, they are also on an “O Circulate” path that surrounds any dancers in the center, and they can do one or more O Circulate actions on that path. (See, for example, the call “Regroup”.) Dancers on that path breathe as necessary to accommodate any center dancers.

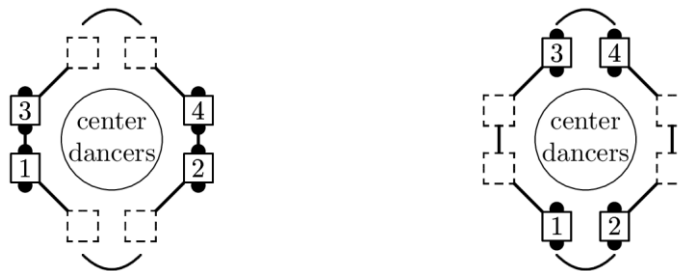

The Very Center Two in any formation may act like the Very Centers of an Hourglass, and vice versa. Any Outsides who are on a center line may act as the other centers of an Hourglass, and vice versa:

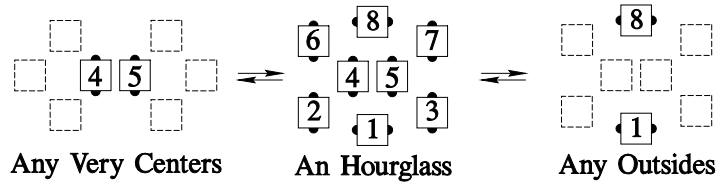

A Wave between vertical Mini-Waves may be treated as a Thar or Wrong Way Thar:

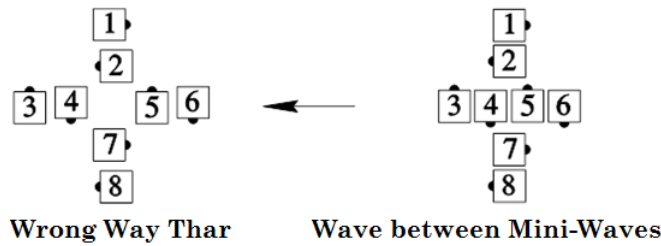

## How Calls Are Extended at C-1

Several calls are used in limited ways at Mainstream, Plus, and Advanced; at C-1, they are used from more places, or are defined more generally.

**<anything> and Spread:** In addition to the ways Spread is used at Plus, there is another way:

If specific dancers are directed to Spread (for example, “Everyone Trade, Boys Spread”), they slide away from the adjacent dancer one position. The inactive dancers do not move. This can be used to create an Hourglass (From #0 Lines: “Touch a Quarter, Column Circulate 1 1/2, Center 6 Trade, Girls Spread”), Blocks (From #0 Lines: “Touch a Quarter, Boys Spread, Check Blocks”), or other formations.

**Circulate:** At C-1, the call Circulate is also defined from Thars, Wrong-Way Thars, Promenade, etc. The circulate paths are as shown here:

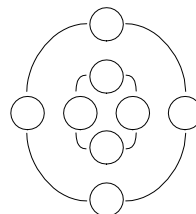

**Cross Over Circulate:** At C-1, Cross Over Circulate uses the following definition, which allows additional starting formations.

In one motion, Circulate and Half Sashay (do your part). During the call, if two dancers would occupy the same space and they are facing the same direction, the Belle goes in front of the Beau; if they are facing each other, they pass right shoulders.

From Facing Couples (for example, Facing Lines or an Eight Chain Thru formation), Cross Over Circulate is danced as a Cross Trail Thru and cannot be fractionalized.

**Recycle:** At C-1, the version of this call that starts from a Wave is defined to have three parts: First, the centers Fold and all adjust to make a Box-Circulate formation. Then all Box Counter Rotate 1/4. Then all Roll. The result is the same as the Mainstream definition.

**Split Counter Rotate:** At Advanced, Split Counter Rotate is proper only from a 2x4 formation (for example, Parallel Waves or Columns), or from Twin or Point-to-Point Diamonds. At C-1, this restriction is removed. The call can begin from any formation that can be divided across its long axis into two side-by-side four-dancer formations with no dancers facing directly toward or away from the center point of their group of four. Each such four-dancer group does a Counter Rotate around the center point of their formation. For example, “Split Counter Rotate” from a Tidal Wave ends in Parallel Waves.

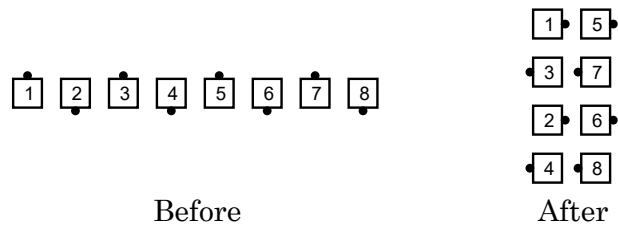

**Switch to a Diamond:** At Advanced, this call is done from a Wave only; at C-1, it may start from a General Line. If the Ends are facing the same way at the start, they meet with right hands, and adjust so the call ends in a Diamond (rather than having the centers offset).



**Switch to an Hourglass:** At Advanced, this call is done from Waves only; at C-1, it may start from General Lines in which the Ends are in Tandem.

## C-1 Definitions

### Ah So

From a Wave or Line: With each half of the Wave or Line working as a unit, the Ends Cross Fold and the Centers follow along so as to keep each Mini-Wave or Couple intact. If the Ends start out facing the same way, they pass right shoulders as they go.

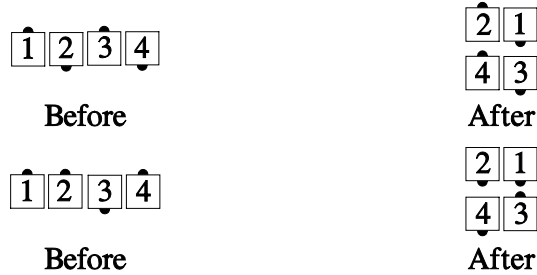

*Teaching Hint:* This call is a more general version of Wheel and Deal—the Centers are just turned around.

### Alter the Wave

Parts: 4

From a Wave: All Swing; the Centers Cast Off 3/4 while the Ends U-Turn Back; all Counter Rotate the Diamond 1/2 (formerly called “turning the Star 1/2”); Flip the Diamond. Ends in a Wave.

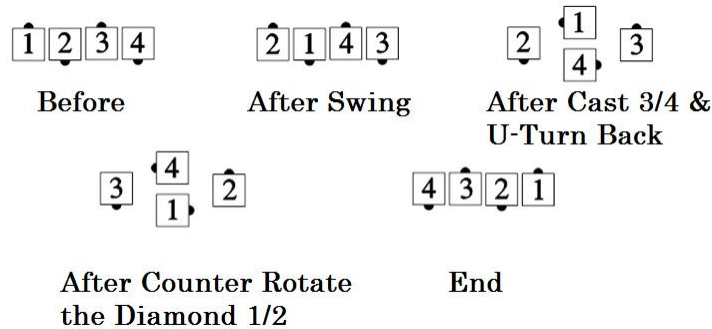

One can also “Counter Rotate the Diamond” by other amounts than 1/2. For example, “Alter the Wave, but Counter Rotate the Diamond 3/4”:

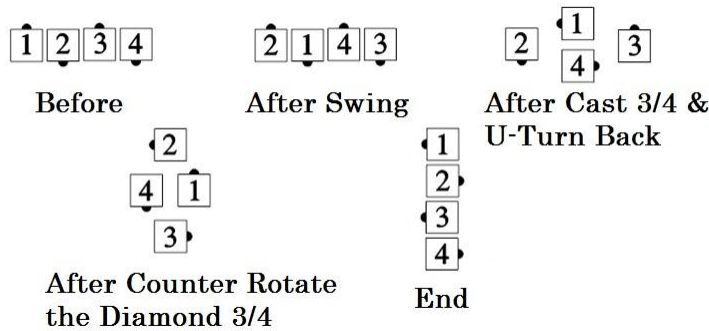

*Teaching Hint:* One can think of the Counter Rotate as two Diamond Circulates (except that the Centers of the Diamond remain Centers throughout).

## Block Formation

A Block is a 4×4 matrix in which no two real bodies have a real body between them. There is one space between all bodies in a Block: in front, in back, left and right.

In Blocks you can do only 4-person calls (or sequences of calls) that start and end in a 2×2 formation, for example, Partner Trade, Partner Tag, Pass Thru, Touch a Quarter, Star Thru, Square Thru, Wheel Thru, etc. When doing a call in a Block, dancers work only with the dancers in their own Block; all Block calls start and end on the same four spots on the floor, for example, “In Your Block, Walk and Dodge”:

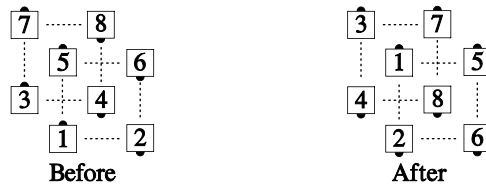

For some calls, the dancers are working in a Wave during the call's action. In that case, the Waves are slightly offset from each other, just as the Blocks are slightly offset, for example, “In Your Block, Square Chain Thru”:

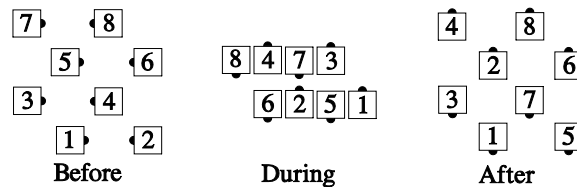

## <main call> But <anything>

This syntax describes a specific modification to <main call> in which one or more parts of <main call> are replaced with <anything>. Some call definitions describe what “But” means when used with that call. (See Percolate, for example.) Otherwise, “But” means that the Centers replace their last part of <main call> with <anything> while the other dancers complete <main call> normally. To use “But” in this way there must be a clear last part for the Centers, it must occur only in the center, and it must not involve interacting with the other dancers.

Example Calls:

- Chain Reaction But 2/3 Recycle (replace the Cast Off 3/4)
- Mini Busy But Cut the Diamond (replace Flip the Diamond)
- Load the Boat But Spin the Top (replace the Centers’ final Pass Thru)

Notes:

1. Callers often use the word “but” in its common English sense simply to warn dancers to listen for a modification, as in “<main call> but <modifying words>”. The words that follow, using modifying terms such as Replace, Omit, Interrupt, Turn the Star, or On the 3rd Hand, describe the details of the modification. Using “but” is completely optional in these usages, and should not be confused with the more specific “But” modifier presented here.
2. While the “But” definition uses the phrase “clear last part for the Centers”, it is not intended to require the call definition to have formally defined parts with language such as “This call has N parts.” “But” is simply intended to be a shorthand replacement for the phrase “Centers Replace the Last Part With” and may be used whenever that phrase would be clear.

3. Calls such as Chain Reaction and Tally Ho have their last part defined by terms other than “Centers”, such as “Those who meet Cast Off 3/4 while the others move up.” The dancers who “meet” and finish the call in the center are considered Centers for the purposes of the “But” modifier.
4. “But” may only be used with 8-dancer calls, and the calls must have multiple parts for the dancers who finish in the center. For example, it is not proper to use “But” with Acey Deucey or Trade By because the Centers have only one part.
5. Some calls that do have a “clear last part for the Centers” may be confusing to use with the simple “But” because they have been traditionally modified in a different way. For example:
  - “Spin the Windmill”. The Centers do have a clear last part (Cast Off 3/4) but callers more frequently modify the Outsides’ part.
  - “Plenty”. The Centers do have a clear last part (1/2 Zoom), but callers more frequently modify the Split Circulates.

Using a simple “But” with these calls to replace the Centers’ last part would likely be confusing to the dancers and is not recommended. Instead, callers should use more explicit terminology, such as “Spin the Windmill Left, Centers replace the Cast Off 3/4 with <anything>.”

Other calls with alternative common modifications include Square the Bases and Pass the Axle. Please refer to those call definitions for the proper use of “But” with those calls.

### **Butterfly and O Concepts**

Butterfly and O *formations* are similar to General Columns, but the dancers occupy 8 specific spots within a 4×4 grid, as shown below.

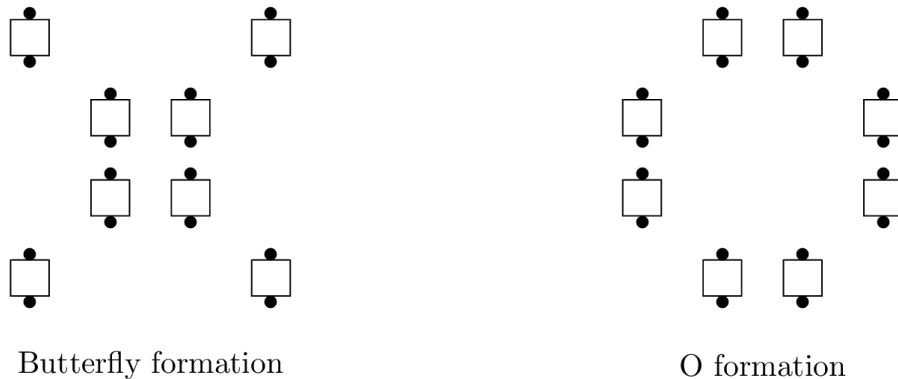

The Butterfly and O *concepts* specify that dancers treat the formation as distorted General Columns and do the specified call accordingly. The Butterfly concept can be used only when dancers are on Butterfly spots; the O concept can be used only when dancers are on O spots.

The Butterfly and O concepts can only be used with calls that start from General Columns (Columns, Double Pass Thru, Eight Chain Thru, etc.) and end in a 2×4 (General Lines, General Columns, or a T-Bone 2×4). The ending formation will always match the result of the dancers adjusting by sliding together as needed to make (undistorted) General Columns, doing the call normally, and then adjusting as needed to collectively occupy the original Butterfly or O spots.

Examples:

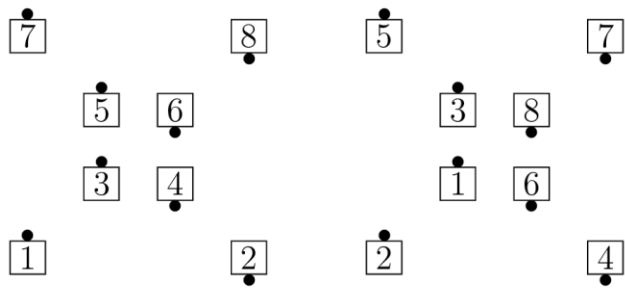

before  
Butterfly Circulate

after

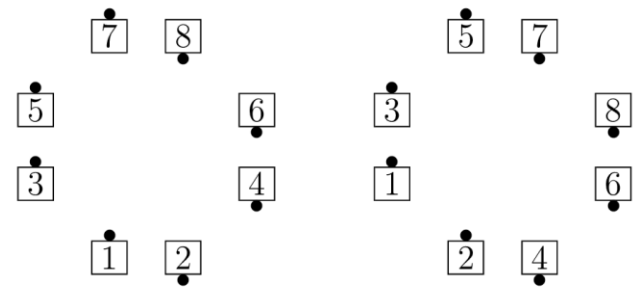

before  
O Circulate

after

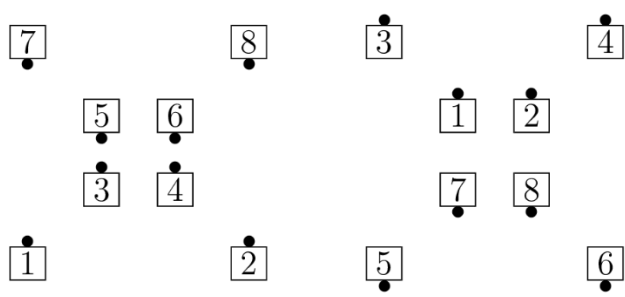

before  
Double Pass Thru

after

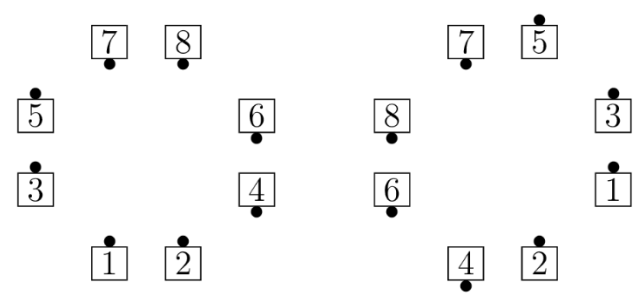

before  
Triple Cross

after

On Box calls such as Walk and Dodge or Split Counter Rotate (below), dancers should make sure to work in their own (distorted) Box, as they would from ordinary (undistorted) Columns.

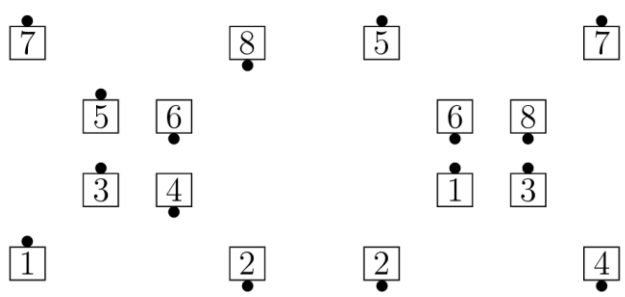

before  
Walk and Dodge

after

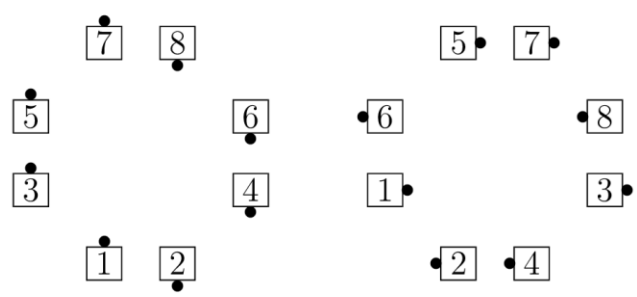

before  
Split Counter Rotate

after

Simpler calls, such as those shown so far, are typically danced by moving directly to the existing spots. For more complex calls, dancers usually blend an initial adjustment to an undistorted General Columns formation with the initial actions of the call, and blend the final actions of the call with a final adjustment from a 2x4 back to Butterfly or O spots. For the Butterfly concept, the new Ends adjust outward; for the O concept, the new Centers adjust outward. In the first pair of examples below, the adjustment is forward or backward from the nominal (undistorted) final 2x4 formation; in the second pair it is sideways.

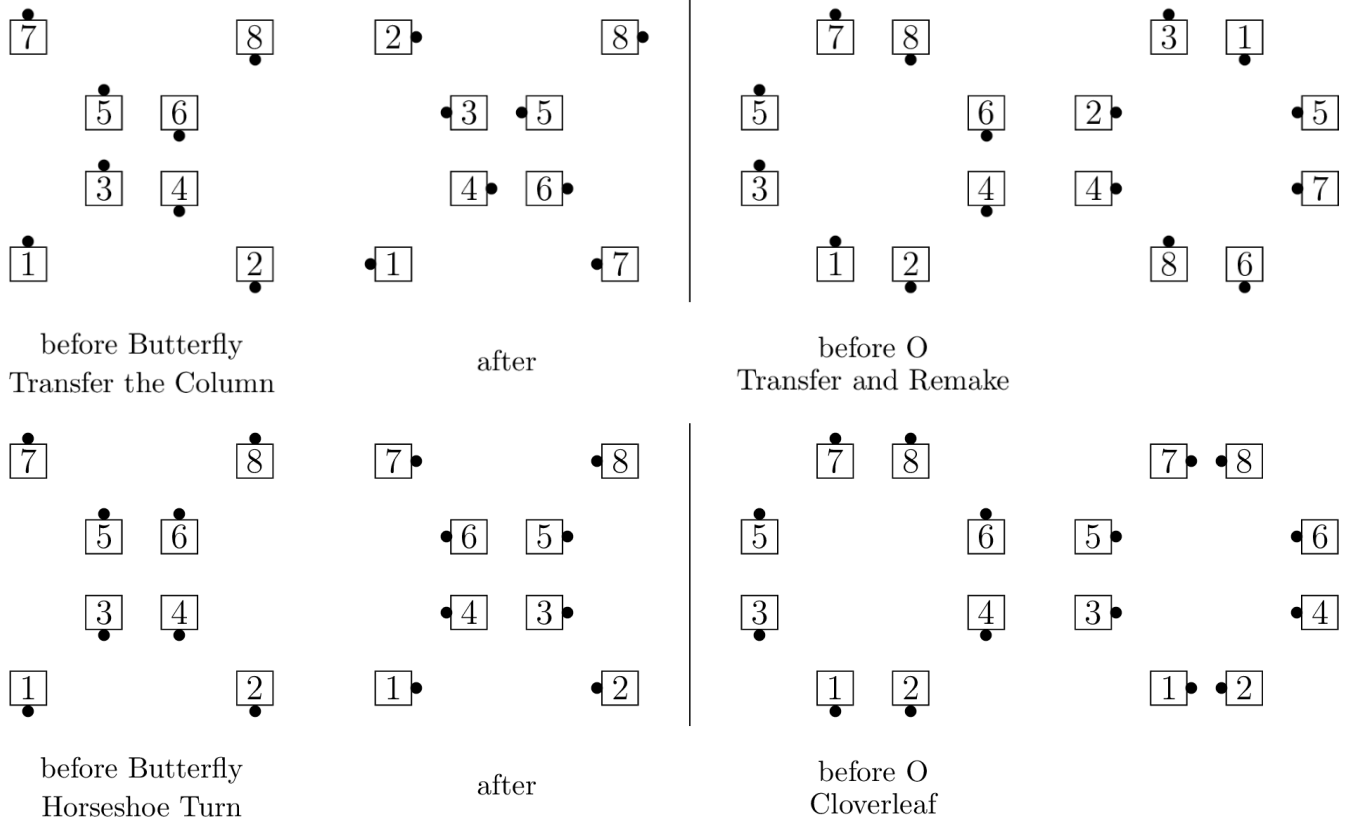

The Butterfly and O concepts always specify that the formation be treated as distorted General Columns, not distorted General Lines or Waves. Wave calls, such as Swing Thru, can be used with these concepts only if the call permits applying the Facing Couples Rule and the starting formation is a Butterfly/O version of an Eight Chain Thru formation. On the calls shown below, the dancers step to a Wave of appropriate handedness, then do the call normally, adjusting at the end to occupy the original eight spots.

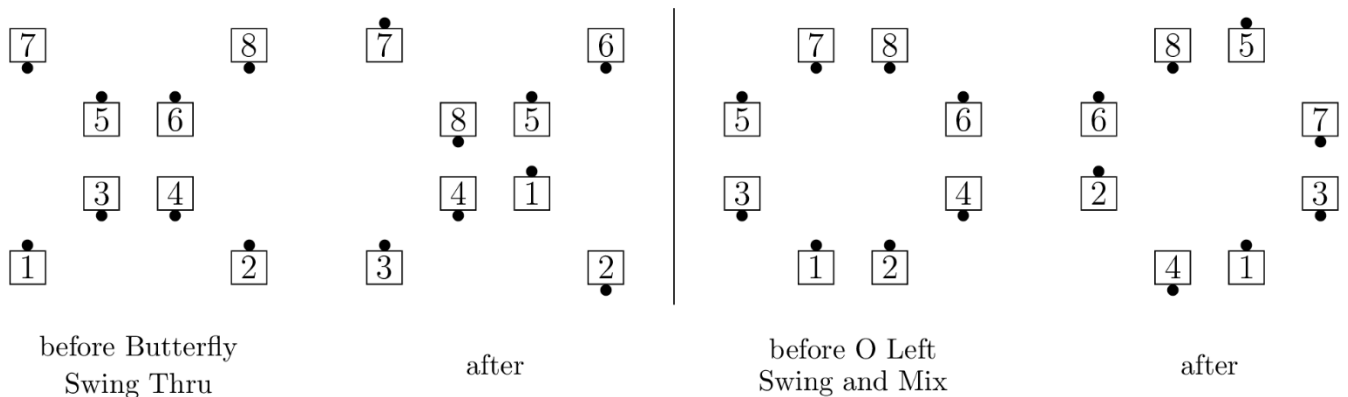

A few other calls can be used from a Butterfly or O formation but are not applications of the Butterfly or O concepts and therefore do not necessarily end back on the same eight spots. Examples include Squeeze, Squeeze the Butterfly, Squeeze the O, and Press Ahead. Callers should avoid phrases that may be interpreted as applying the Butterfly or O concepts when this is not intended. If, for example,

the caller wishes to draw attention to the formation before using a call such as Press Ahead, a cue such as “Check a Butterfly” or “You have an O” may be used. However, the expressions “In Your Butterfly” or “In Your O” are typically interpreted as specifying the corresponding concept; they should only be used if that concept is intended.

The terms “T-Bone Butterfly” and “T-Bone O” describe formations in which dancers are on Butterfly Spots or O Spots but there are dancers, not necessarily adjacent, whose facing directions are perpendicular. If the Butterfly or O Concept is used when dancers are in a T-Bone Butterfly or O, each dancer works in their own Butterfly or O, as if the other dancers were not T-boned to them. (See “T-Bone Formation” for a broader discussion of doing calls from T-Bone formations.)

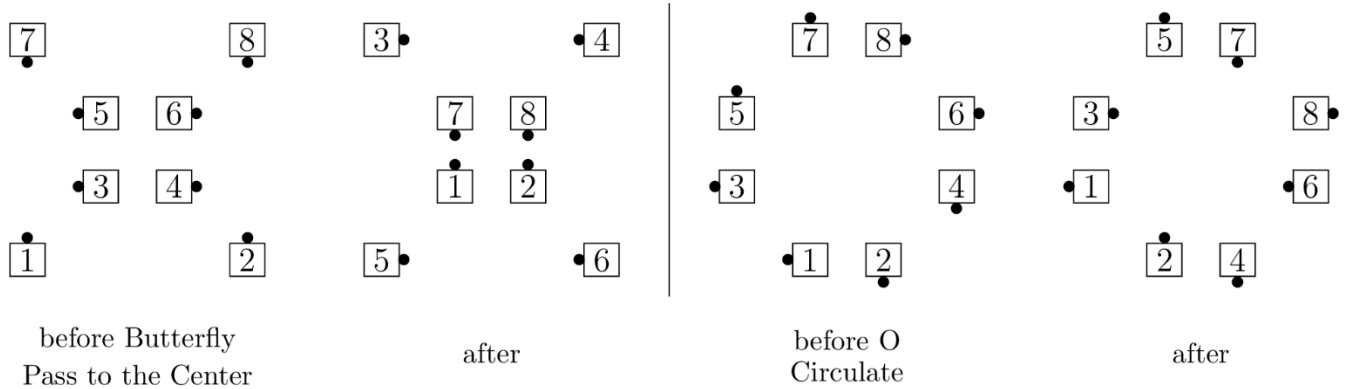

Other more specific formation names are also used. For example, a Butterfly Double Pass Thru formation is a Double Pass Thru formation distorted to occupy Butterfly Spots, and an O Eight Chain Thru formation is an Eight Chain Thru formation distorted to occupy O Spots.

**Cast Back / Cross Cast Back**

**Cast Back**

From any formation with definite Leaders, who must not be facing directly toward or away from the flagpole center: Starting in a Tandem, the Lead dancer always does the call; elsewhere, the caller must designate a dancer. The designated dancer does a Peel Off and steps forward to stand beside the other dancer. The other dancer does not move. This call cannot be fractionalized.

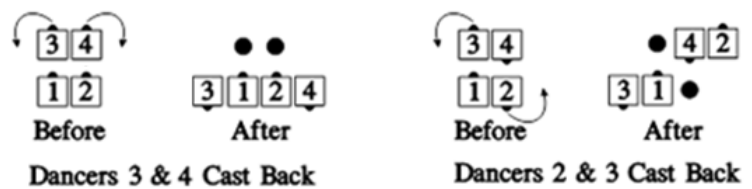

**Cross Cast Back**

From a Couple facing out of a 2x2 formation: Starting in Tandem Couples, the Lead dancers always do the call; elsewhere, the dancers must be designated. The designated dancers Trail Off and step forward to stand beside the other dancers. The others do not move. This call cannot be fractionalized.



**Chain Reaction**

Parts: 4

At C-1, the restrictions from the Advanced Program on the formations from which you may call Chain Reaction are removed. In effect, this adds 1/4 Lines and a Two-Faced Line or a Wave between Parallel Mini-Waves to the list of starting formations. Examples:

Right-Hand 1/4 Line:

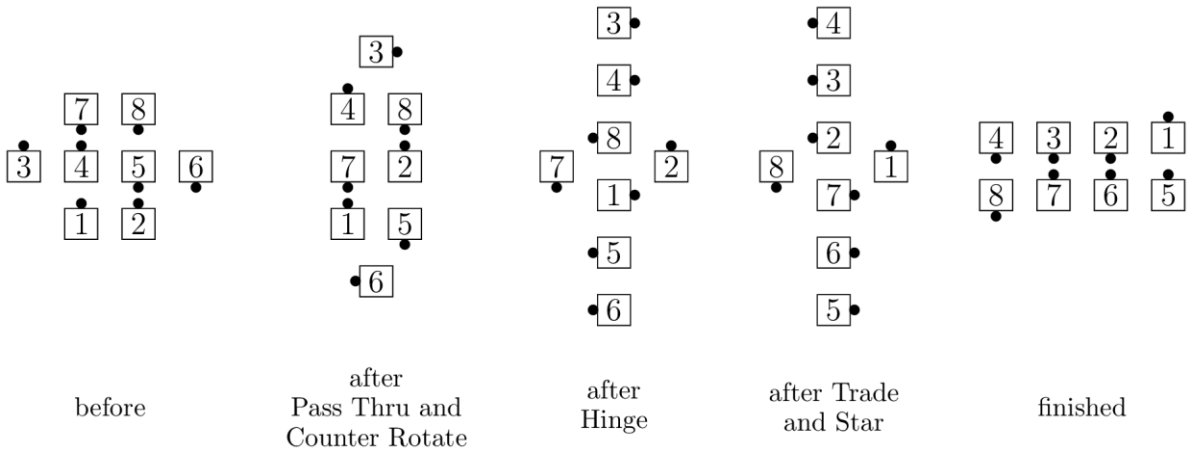

Two-Faced Line between Mini-Waves.

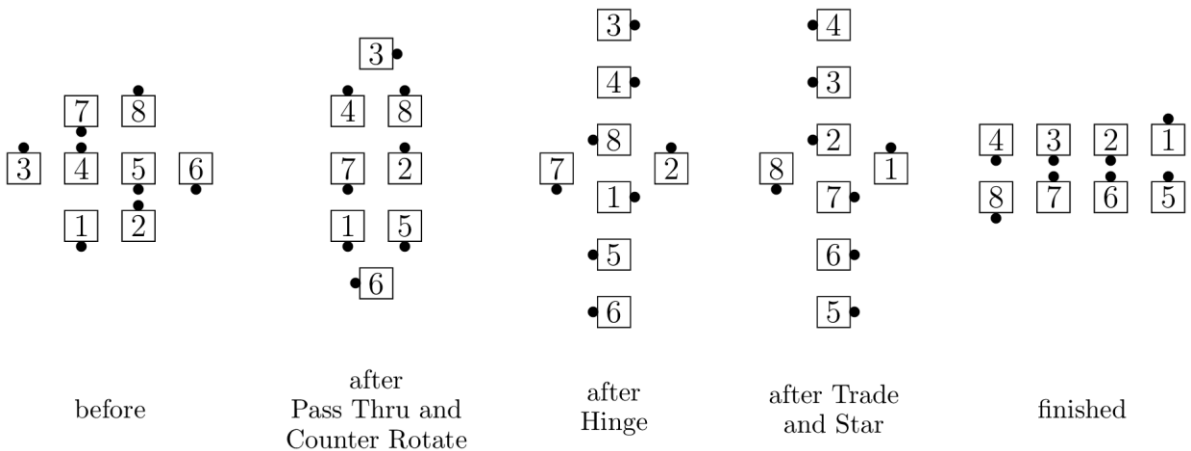

**Chase Your Neighbor**

Parts: 2

From Back-to-Back Couples only: In one smooth motion, Belles U-Turn Back to the right and all Box Circulate; Follow Your Neighbor. Ends in a Left-Hand Wave. This call feels like beginning a Chase Right and blending into a Follow Your Neighbor.

**Chase Your Cross Neighbor**

From Back-to-Back Couples only: In one smooth motion, Belles U-Turn Back to the right and all Box Circulate; Cross Your Neighbor. Ends in a Left-Hand Two-Faced Line. This call feels like beginning a Chase Right and blending into a Cross Your Neighbor.

**Checkover**

From Columns: The #1 and #2 dancers Checkmate while dancers #3 and #4 Circulate, Cast Off 3/4, Slither, and As Couples Extend. Ends in Parallel Two-Faced Lines.

**Circle By <m> and <n>**

Parts: 2

From Facing Couples: This call requires that two fractions, <m> and <n>, be called as part of its name, for example “Circle By 1/4 and 1/2”. All join hands and Circle Left <m> and Touch; Cast off <n>. If n is “Nothing”, you just step to a Wave. The second fraction <n>, may be replaced by another call as in “Circle by 1/2 and Recycle”. In that case, the Cast Off is replaced by the call specified. In this example, the dancers would Circle Left 1/2 and Touch, then Recycle, ending in Facing Couples.

**Concentric Concept**

From any appropriate formation (half the dancers must be Centers and half must be Outsides): The Centers do the call in their group, while the Outsides work with each other and do the call around the outside. The first set of diagrams, showing seven starting formations, illustrates who works with whom on a Concentric call. These are not the only possibilities; other starting formations may be used, as long as it is clear which dancers work together and each group can do the specified call.

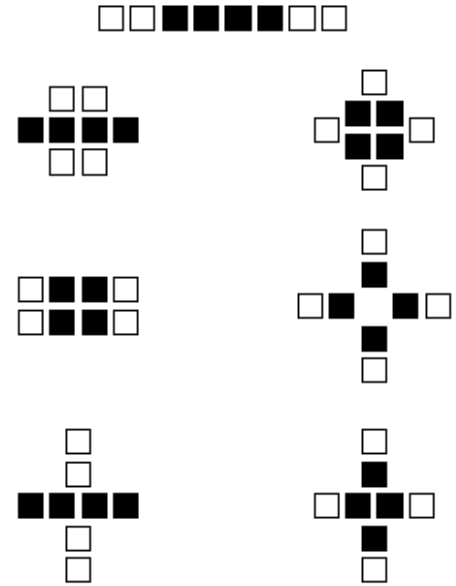

The bottom two formations shown are really the same; the grouping on the left is used if the caller only says “Concentric...” and the Concentric call can be done from a 1x4. The grouping on the right is used when the caller says “Concentric Diamond ...” or when the Concentric call can only be done from Diamonds (for example, “Concentric Diamond Circulate” or “Concentric Flip the Diamond”).

If the Concentric call starts and ends in a 2x2 Box (for example, “Concentric Star Thru”), the following rule applies: If the Outsides begin as though in Columns, they finish as though in Columns; if they begin as though in Lines, they finish as though in Lines.

**Concentric Star Thru:**

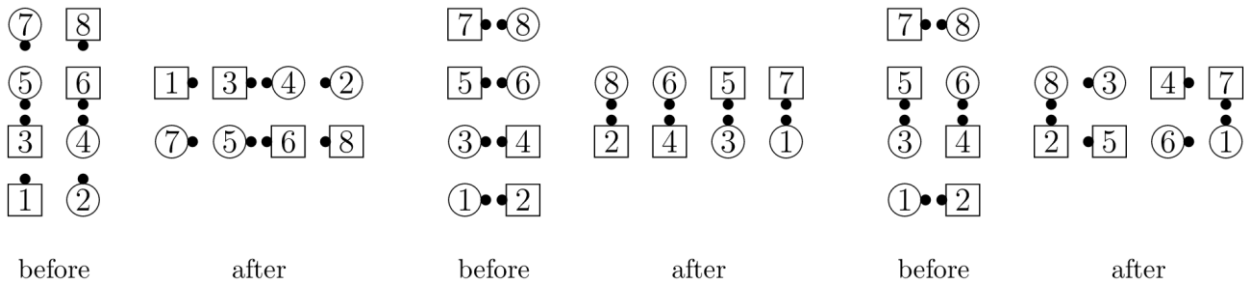

If the Concentric call ends in a 2x2 Box but starts elsewhere (for example, “Concentric Recycle” from a Tidal Wave), the following rule applies: The Outside dancers finish so that the long axis of their ending formation is at right angles to the long axis of their starting formation.

Concentric Recycle:

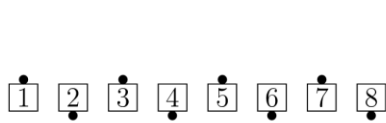

before

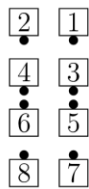

after

Concentric Recycle:

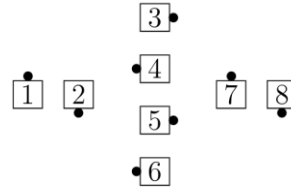

before

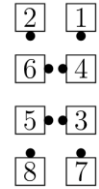

after

Concentric Reverse Explode:

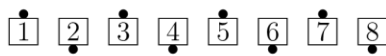

before

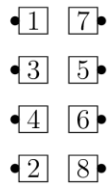

after

Concentric Hinge:

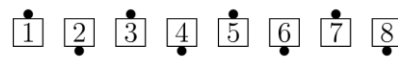

before

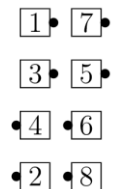

after

Concentric Step and Fold:

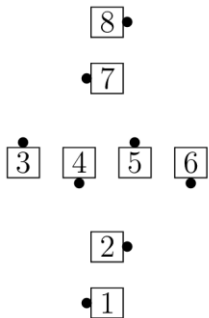

before

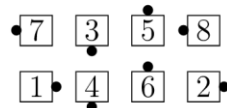

after

Concentric Diamonds, Step and Fold:

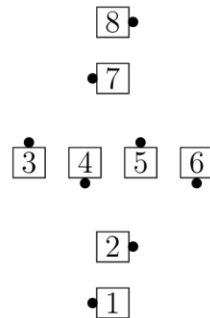

before

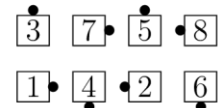

after

If the Concentric call does not end in a 2x2 Box, then it is not necessary to apply either of the above rules. The Outsides simply finish in the outside 1x4 or Diamond.

Concentric Trade the Wave:



before

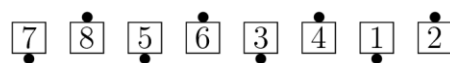

after

Concentric Recycle:

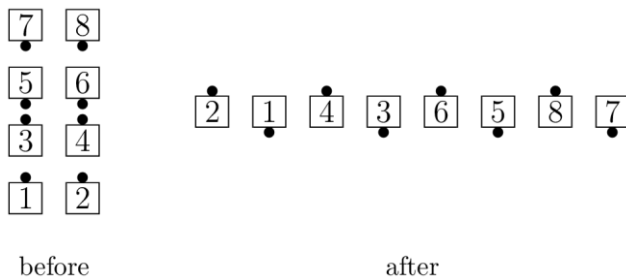

Concentric Switch to a Diamond:

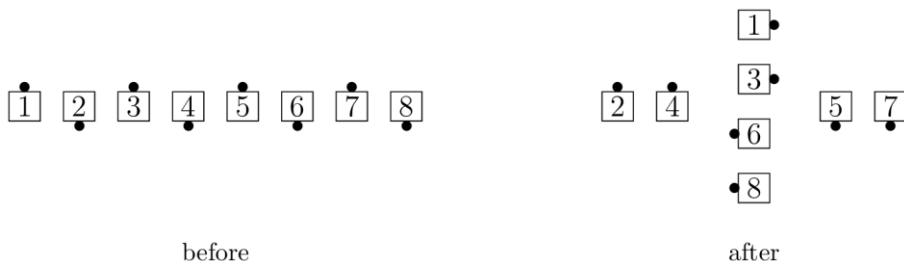

If the Concentric call involves applying the Ocean Wave Rule or Facing Couples Rule, the Concentric rules apply to the actual starting formation, not to any adjusted formation that might be created or imagined while starting the call.

Concentric Square Thru 3:

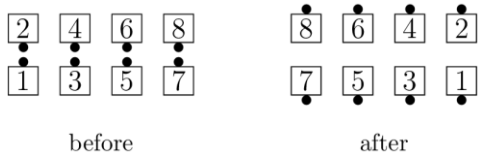

Concentric Square Thru 3:

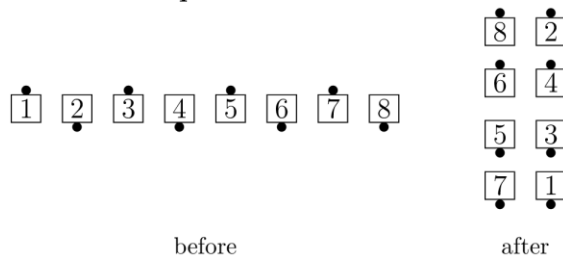

The following example begins from Concentric Z's. Dancers 1, 4, 5 and 8 are in the Center Z. Concentric Z's are not commonly used and can be difficult for the dancers to see because a Center Line, Wave, or Column is also present. Caller judgment is required.

Concentric Peel Off:



Common applications of Concentric include:

- From starting Double Pass Thru: Star Thru, Slide Thru, Pass In, Pass Out, Touch a Quarter
- From Completed Double Pass Thru: Chase Right, Shakedown
- From Tidal Wave: Recycle, Ah So
- From Tidal Line: Wheel and Deal, Turn and Deal, Half Tag

### Counter Rotate

From any formation with no dancers facing directly toward or away from the flagpole center: Each dancer moves forward the designated number of quarters (1/4 unless otherwise specified) around the flagpole center of the formation, staying the same distance from that center as though moving on a wheel turning about that center. With each quarter a dancer Counter Rotates, the dancer faces a new wall (turns 90 degrees).

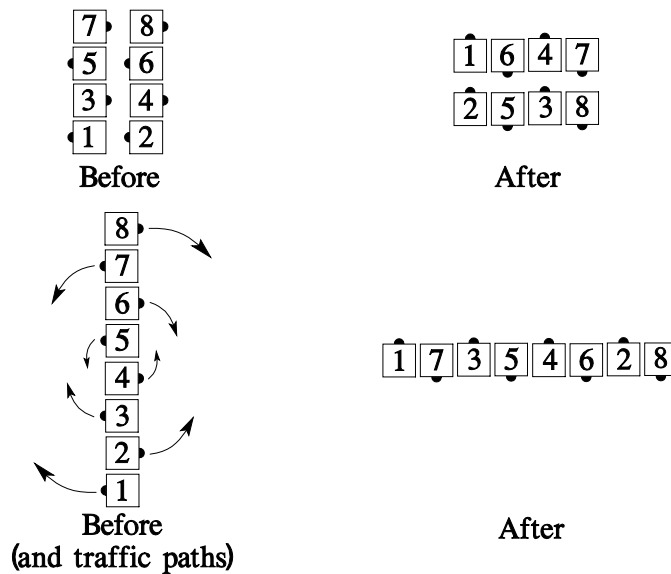

The original outsides always finish as outsides, and the original centers always finish as centers. For example, “Points Counter Rotate 1/4”:

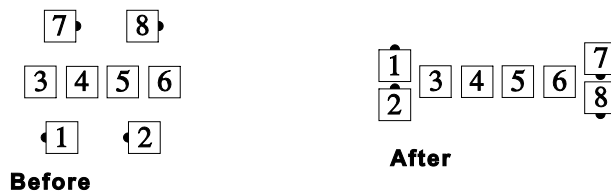

*Teaching Hint:* From Parallel Waves, people tend to try to Split Counter Rotate. Describing the action, from that formation only, as “Concentric Box Counter Rotate” helps a great deal.

Also see **Split Counter Rotate** in the section on “How Calls are Extended at C-1” (page 13).

## Cross and Turn / Reverse Cross and Turn

### Cross and Turn

From Facing Couples: The Beaus Right Pull By with each other as the Belles U-Turn Back. Ends in Couples Back-to-Back.



### Reverse Cross and Turn

From Facing Couples: The Belles Left Pull By with each other as the Beaus U-Turn Back. Ends in Couples Back-to-Back.

## Cross By

From a Thar, Wrong-Way Thar, or Parallel Waves: 1/2 Circulate, Sashaying as you go, and joining opposite hands from initial handhold. Ends in a Wrong-Way Thar, Thar, or a Wave between vertical Mini-Waves.

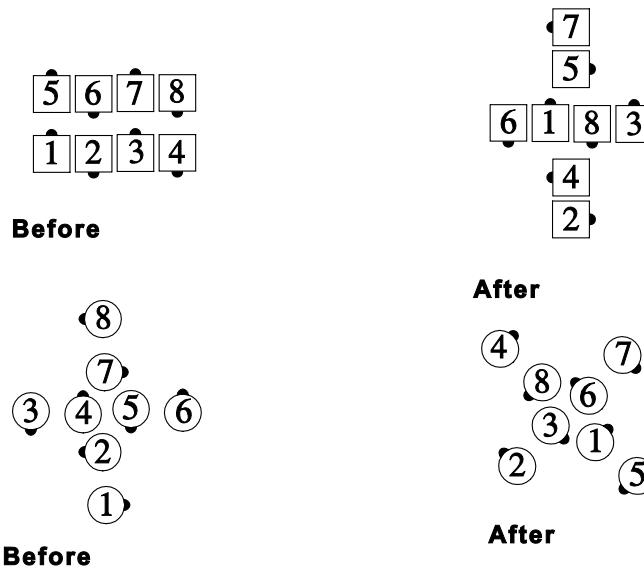

## Cross Chain Thru / Cross Chain and Roll

### Cross Chain Thru

Parts: 2

From Eight Chain Thru: All Right Pull By, then the Ends Courtesy Turn while the Centers Left Hand Star 1/2 to end in another Eight Chain Thru formation. The Star ends as though the Centers had done a Cross Trail Thru.



Note: By definition, "Cross Chain Thru and Roll" is the same as Cross Chain and Roll.

### Cross Chain and Roll

Parts: 2

From Eight Chain Thru: All Right Pull By. The Outsides Courtesy Turn and Roll while the Centers Left Hand Star 1/2, to end in Parallel Waves.



### Cross Extend

From a Single 1/4 Tag or Box Circulate: Extend but move on a slight diagonal so as to end in a formation whose handedness is the opposite from that of the starting formation. Cross Extend from a Right-Hand Single 1/4 Tag ends in a Left-Hand Box Circulate. Cross Extend from a Right-Hand Box Circulate ends in a Left-Hand Single 3/4 Tag.

Notes: Cross Extend is a 4-dancer call. The common 8-dancer starting formations are a 1/4 Tag and Parallel Waves.

From a 1/4 Tag, since those in the center Wave are most aware of its handedness, it is important for them to meet the outside dancers with the correct hand.

From Parallel Waves there is a tendency for the original Leaders to cross or Half Sashay with each other. This would be incorrect because the two Box Circulate formations should not interact. The original Leaders simply move straight ahead and adjust to form a Couple in the resulting 3/4 Tag formation.

### Cross Roll to a Wave / Line

From a Line or Wave: The Centers Cross Run while the Ends Run. The Centers pass outside of the Ends as they Cross Run.

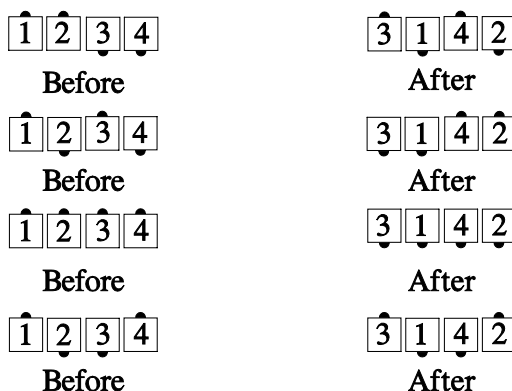

**Cross Your Neighbor**

From a Box Circulate: The Trailers Cross Extend and Arm Turn 3/4 while the Leaders do your part of Follow Your Neighbor. Cross Your Neighbor cannot be fractionalized.

From a Single 1/4 Tag: all dancers do the Trailers part (Cross Extend and Arm Turn 3/4).

**Pass and Roll Your Cross Neighbor**

From Single Eight Chain Thru: All Pass Thru. The Centers Turn Thru while the Outsides do a right-face U-Turn Back. All begin a Pass Thru, blending smoothly into Cross Your Neighbor (equivalent to Pass Thru; Centers Left Touch 3/4 while Outsides right-face U-Turn Back and Roll). Ends in a Left-Hand Two-Faced Line.

Note: There is no consensus on the parts of this call or on how many parts it has. It does have a definite first part (All Pass Thru), so “Finish Pass and Roll Your Cross Neighbor” is proper, but fractionalizing this call or referring to any part except the first is not proper.

**Diamond Chain Thru variation**

**<anything> Chain Thru**

after <anything>: Parts: 2

All do the <anything> call, then the Very Centers Trade and the Center Four Cast Off 3/4. If the <anything> call is a Triangle or Diamond Circulate, the word “Circulate” is conventionally omitted (for example, “Inpoint Triangle Chain Thru” or “Interlocked Diamond Chain Thru”).

**Dixie Diamond**

Parts: 2

From Facing Couples or Facing Tandems: Dixie Style to a Wave; the Centers Hinge while the Ends U-Turn Back (turning toward each other). Ends in a Right-Hand Diamond.

**Dixie Sashay**

Parts: 2

From Facing Couples or Facing Tandems: Dixie Style to a Wave; Slither. Ends in a Left-Hand Two-Faced Line. (Dancers should anticipate the Slither action and blend smoothly into it from the Left Touch a Quarter action that concludes Dixie Style to a Wave.)

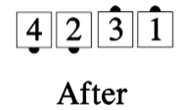
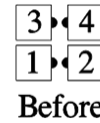

**Flip the Line (1/4, 1/2, 3/4, Full)**

From a Wave only: Centers Run and all any-shoulder Tag the Line the given fraction (1/4, 1/2, 3/4, Full). “Any-shoulder” means: From a Right-Hand Wave, use a right shoulder pass; from a Left-Hand Wave use a left shoulder pass.

**Follow Thru**

From a Box Circulate, T-Bone Box, or Single Quarter Tag: All 1/2 Scoot Back. Ends in a Wave, Two-Faced Line, or Diamond.

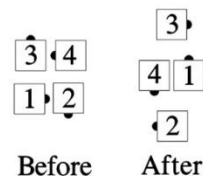
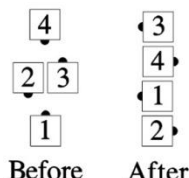
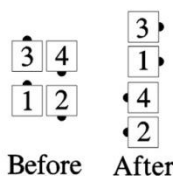

**Galaxy Formation / Circulate / Cut / Flip**

**Galaxy Formation**

A Galaxy is composed of a Center Box and an Outside Diamond.



**Galaxy Circulate**

From a Galaxy: Each dancer moves forward one spot along the circulate path as shown.



**Cut the Galaxy**

From a Galaxy: Centers Galaxy Circulate while the Points slide together and Trade (Star 1/2). Finishes in a Thar Star or Promenade.

**Flip the Galaxy**

From a Galaxy: Centers Galaxy Circulate while the Points Run to the nearest center. Finishes in a Thar Star or Promenade.

**Interlocked Diamond Formation**

Two adjacent Diamonds in which the Very Centers work with the furthest other 3 dancers.

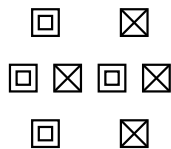

Interlocked Diamonds (Twin)



Interlocked Diamonds (Point-to-Point)

**Interlocked Diamond Circulate**

Diamond Circulate to the next position in your Interlocked Diamond.

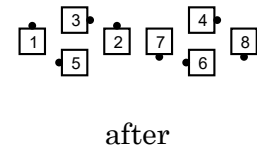
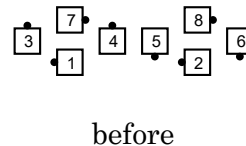
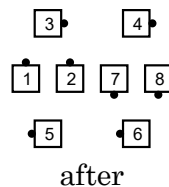
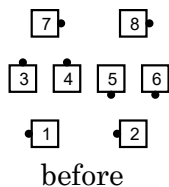

**Cut the Interlocked Diamond**

From Interlocked Diamonds (Twin): The Points Cut the Diamond, while the Centers Interlocked Diamond Circulate.

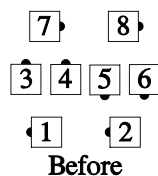

**Flip the Interlocked Diamond**

From Interlocked Diamonds (Twin): The Points Flip the Diamond, while the Centers Interlocked Diamond Circulate.



**Jaywalk**

From dancers facing directly or on an angle: Like a Pass Thru, except the dancers do not have to be facing directly. Each dancer finishes on the other dancer's starting spot, facing opposite the way that dancer was facing.

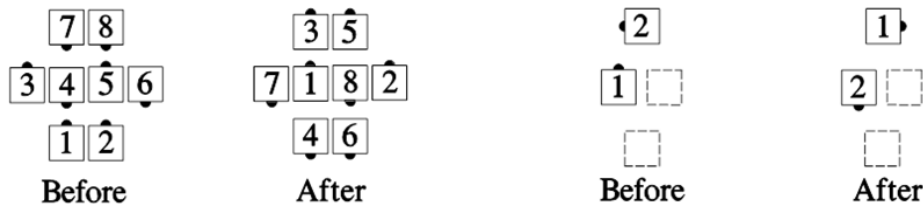

**Linear Action**

Parts: 3

From 1/4 or 3/4 Tag, Wave between Parallel Mini-Waves, 1/4 or 3/4 Line, or Two-Faced Line between Parallel Mini-Waves: All Hinge. Centers Box Circulate 1 1/2, as outsides Trade. Those who meet Cast Off 3/4, as others move up (as in Hourglass Circulate) to form Parallel Waves or Lines.

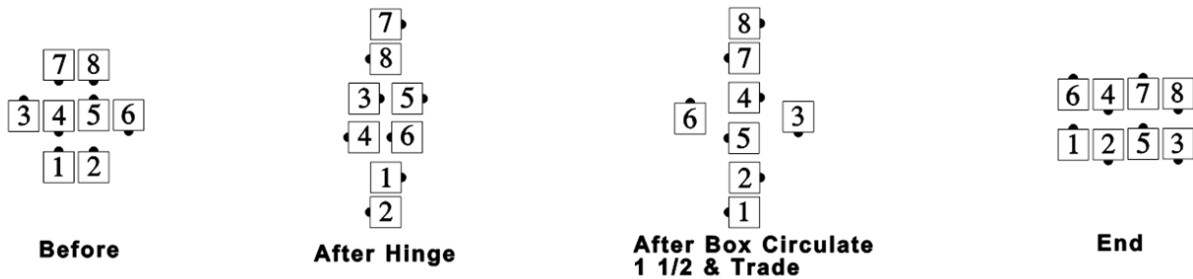

**Magic Column Formation / Concept**

A Magic Column consists of the Ends of one Column and the Centers of the other Column. The dancers act as though they were in a Column together, beginning and ending on those four spots.

Do the call as usual, but if you move from End to Center or Center to End, follow the Magic Column Circulate path. Note that a single Magic Column is neither right- nor left-handed. You must follow the Magic traffic pattern, and perform any action using the hand appropriate to your position at that point in the call.

**Magic Column Circulate**

From Magic Columns: Each dancer moves forward along one of the two circulate paths shown at right:

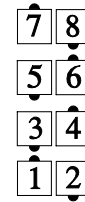
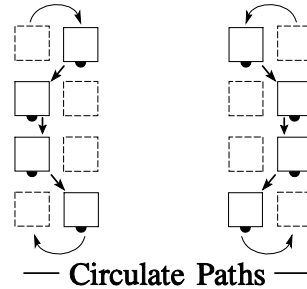

Before

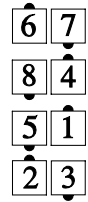

After

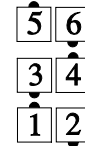
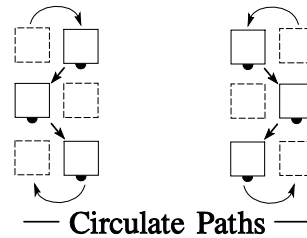

Before

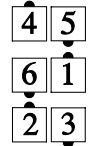

After

If an End and a Center are facing each other, they pass using the End's inside shoulder (the Center dancer moves first). This takes the place of the right-shoulder rule. So "Magic Column Circulate 1 1/2" would end like so:



Before

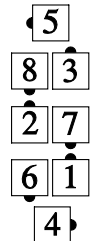

After

*Teaching Hint:* You can point out that the Ends are holding opposite hands from the Centers—for example, the Ends have right hands joined, and the Centers have left hands joined.

If you leave the circulate path (for example, in "Magic Column Transfer", shown below), just finish the call as usual. In this example, the ending Wave is left-handed because the Centers have lefts before the final Extend:

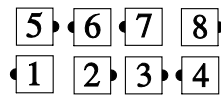

Before

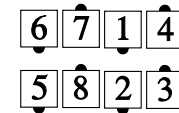

After

In the case of "Magic Column Walk and Dodge", the rules are the same: Those who are doing the Walk follow the circulate path, and those doing the Dodge (and thus leaving the circulate path) just slide sideways as usual:

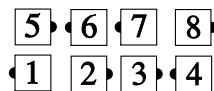

Before

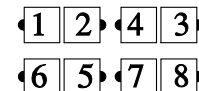

After

Note: Magic Column calls are only permitted where complete Magic Columns exist. It would be improper, for example, to call "Magic Walk and Dodge" from an Inverted Box in isolation.

Note: At C-1 this concept is restricted to Right or Left-Hand Magic Columns only.

### Make Magic

From General Columns: Any Center and Outside dancers who are facing each other do a Pass Thru, as any Center who is facing in, does a pull by with the diagonally opposite dancer, using outside hands. If all four Centers are facing in, they Cross Trail Thru.

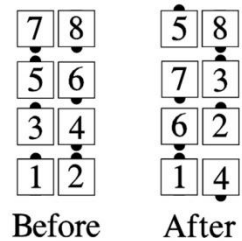

### O Concept

See “Butterfly and O Concepts”.

### Pass the Axle / The Axle

#### **Pass the Axle**

Parts: 4

From Eight Chain Thru: All Pass Thru; the Centers Pass Thru while the Ends Cross Cast Back; All Swing; the new Centers Trade.

#### **The Axle**

Parts: 3

From Trade By or Completed Double Pass Thru: The Centers Pass Thru, if they can, while the Ends Cross Cast Back; All Swing; the new Centers Trade.

#### **(Pass) The Axle (but) Cast (Off) N/4**

Replace the Swing with Cast Off N/4. Some callers prefer to omit the “but” to avoid possible confusion with the general “But” modifier (page 16, and below). Other callers prefer to include the “but” to make it clear this is a modification.

#### **(Pass) The Axle But <anything>**

For an <anything> call that is not “Cast (Off) N/4,” this follows the general “But” modifier (page 16). The Centers replace their final Trade with <anything>. Example: “Pass the Axle But Chase Right”.

Note: There is no ambiguity between the two possible usages of “but” here because the call “Cast Off N/4” is not a suitable replacement for the Centers’ final Trade.

### Percolate

Parts: 3

From appropriate Parallel Waves or Lines, or Eight Chain Thru formation: Circulate; 1/2 Circulate; the Center Four (those in the Wave) Hinge and Cross while the Ends Turn Thru or Left Turn Thru as appropriate. From most places (for example, Parallel Waves) this ends in Lines Back-to-Back. It can be done from anywhere the Circulate, 1/2 Circulate gives a definite center Wave.

#### **Percolate But <anything>**

“Percolate But” means the Hinge and Cross is replaced by the “But” call. The Ends complete the call as usual.

**Phantom Formation / Concept**

A Phantom is a non-existent dancer with whom real dancers may be asked to work. A Phantom formation (for example, after “Heads Wheel Thru, Swing Thru, Heads Hinge”) has the dancers arranged as shown below. Some of the dancers are in Lines at the head, and some are in Lines at the side. Dancers act as though they are in Parallel Waves or Lines with all the Phantom positions occupied by real dancers.

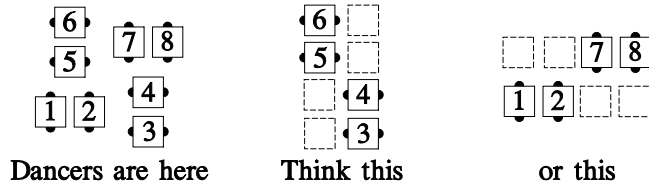

It is also possible to have a Phantom formation where some of the dancers feel like they're in Columns (as below). However, this variation is not appropriate for use at C-1.

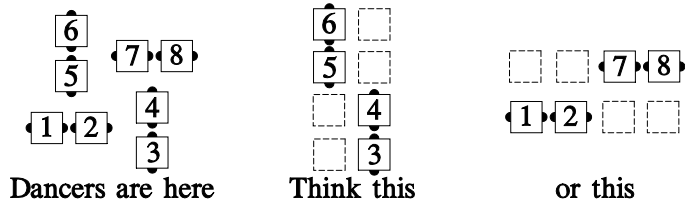

Phantom Circulate:

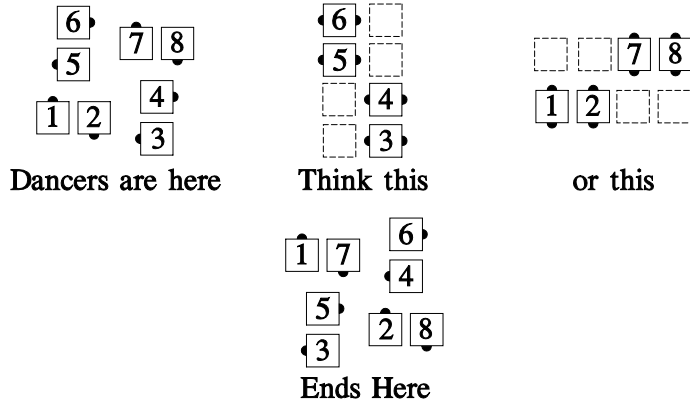

Common applications include Couples Circulate, Cross Over Circulate, Tag the Line, Turn and Deal, Wheel and Deal, Ferris Wheel, Acey Deucey, Trade the Wave, Recycle, Ah So, Circulate, and Trade Circulate.

**Press Ahead**

From any appropriate formation: Those designated move one dancer position forward. Example: #1 Press Ahead:

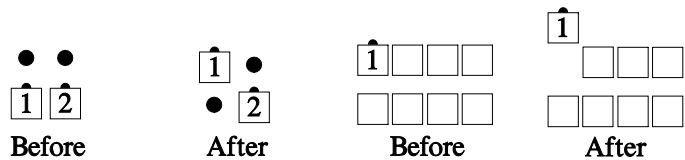

Note: This is not the same as Extend.

## Recycle variations

### All 8 Recycle

From a 1/4 Tag, or Wave between Parallel Mini-Waves: The Centers do a Recycle, working wider than normal, and ending on the outside. Meanwhile, the Outsides move into the center and Recycle (Facing Couples Recycle or Box Recycle, as appropriate), ending in the center. This ends in a 1/4 Tag.



### 2/3 Recycle

Parts: 2

From a Wave only: Do the first two parts of Recycle, that is, Centers Fold (and all adjust to a Box Circulate formation), then Box Counter Rotate 1/4.



### Split / Box Recycle

From Box Circulate formation: Without letting go hands with the Leaders, the Trailers Extend and U-Turn Back, to end with their original outside hands joined. The Leaders follow along, becoming the Ends of the resulting Wave.



From 2x2 formations where half the Box is a Couple and the other is a Right-Hand Mini-Wave: Those in the Couple do a Facing-Couples Recycle, and those in the Mini-Wave do a Box Recycle. This ends in a Right-Hand Wave.



This can't be done when the Mini-Wave is left-handed:



The name "Split Recycle" is used from a 2x4 formation to specify that each 2x2 Box does a Box Recycle.

Where not otherwise ambiguous, it is permissible to call simply, "Recycle" when you mean "Split Recycle", "Box Recycle", or "Facing Recycle". For example, from Columns, you could call "Outsides Partner Tag while the centers Recycle" and the meaning is clear. From Parallel Waves, though, "Recycle" and "Split Recycle" are different because the first applies Recycle to each Wave and the second applies Recycle to each Box.

**Regroup**

Parts for Centers: 2

From Parallel Lines or any other formation in which the Centers are Couples or Mini-Waves and the Outsides can act as Ends of Lines: The Centers Trade and Roll while the Outsides Quarter Out, Trade, and O Circulate. (See “When the Formation Isn’t There”, page 8, for the interpretation of Ends of Lines and O Circulate when the formation isn’t a 2x4.) From Parallel Lines, Regroup ends in Facing Lines.

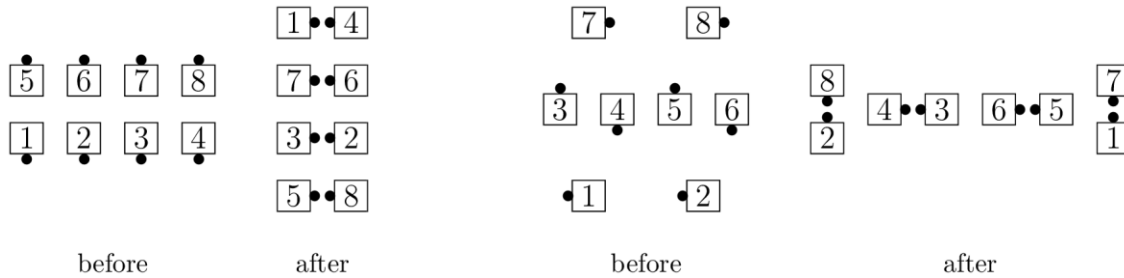

**Relay the Shadow**

From a Tidal Wave: All Swing. The Center Six Cast 3/4, while the Ends Counter Rotate 1/4, meet the Very Centers, Single Hinge and Spread. The other four do the Centers' part of a Cast a Shadow (that is, Leaders “Shadow”, Trailers Extend, Hinge, and Extend).

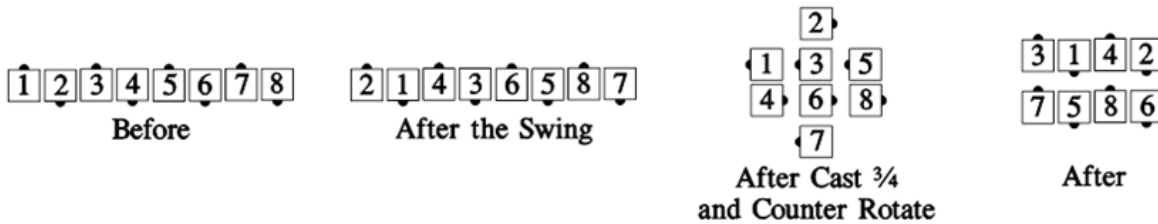

**Relay the Top**

Parts: 4

From Parallel Waves: All Swing. The Centers Arm Turn 3/4 while the Ends 1/2 Circulate, to create a Star between two Mini-Waves. The Star turns 1/4, while the others Trade. The Center four dancers in the 6-person Wave now Cast Off 3/4, while the others move up (as in Hourglass Circulate). Ends in Parallel Waves.

**Reverse Explode**

From a Wave: All Step Thru and Quarter Out. Ends in Couples Back-to-Back.



**Rotary Spin**

Parts: 2

From Eight Chain Thru: Everyone does a Right Pull By, then the Centers step to a Left-Hand Wave and Cast Off 3/4 while the Ends Courtesy Turn and Roll. Ends in Parallel Right-Hand Waves.



**Rotate Family**

At C-1, the following calls are used only from a Static Square or any other formation in which the designated dancers can act as Ends of General Columns (see “When the Formation Isn’t There”, page 8). The designated dancers must be named explicitly to avoid confusion with other Rotate applications that involve all eight dancers (not part of the C-1 program).

- For Rotate and Reverse Rotate, the designated dancers must be Couples.
- For Single Rotate and Reverse Single Rotate, the designated dancers must be Couples or in Mini-Waves.
- These calls all include a fraction, which is required.

**Rotate / Reverse Rotate**

**Rotate 1/4, 1/2, 3/4**

Working As Couples, the designated dancers turn 1/4 in place to face promenade direction and Counter Rotate the given fraction around the outside of the square, while the other dancers move into the middle if they are not already there.

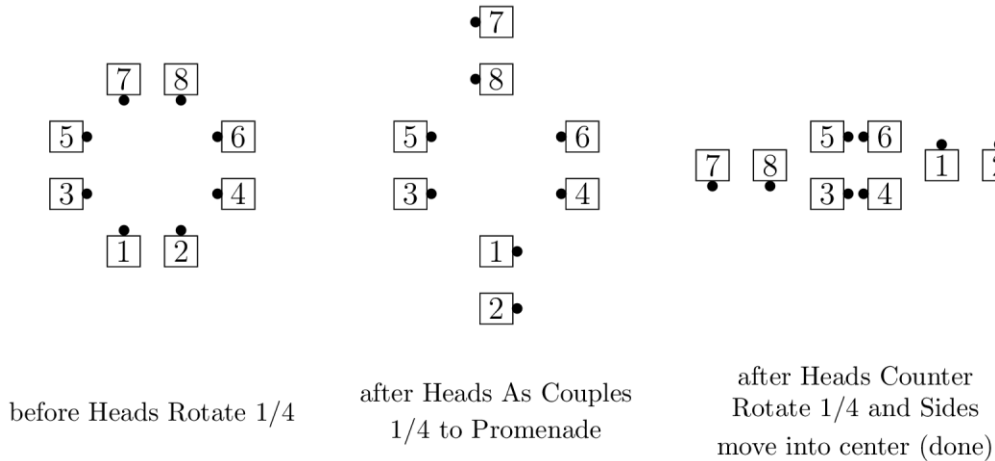

**Reverse Rotate 1/4, 1/2, 3/4**

Working As Couples, the designated dancers turn 1/4 in place to face reverse promenade direction and Counter Rotate the given fraction around the outside of the square, while the other dancers move into the middle if they are not already there.

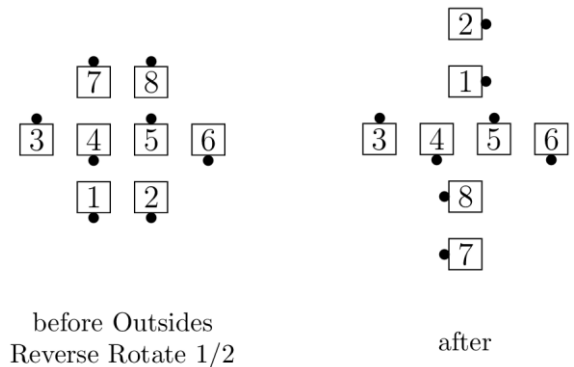

**Single Rotate / Reverse Single Rotate**

**Single Rotate 1/4, 1/2, 3/4**

Working individually, the designated dancers turn 1/4 in place to face promenade direction and Counter Rotate the given fraction around the outside of the square, while the other dancers move into the middle if they are not already there.

**Reverse Single Rotate 1/4, 1/2, 3/4**

Working individually, the designated dancers turn 1/4 in place to face reverse promenade direction and Counter Rotate the given fraction around the outside of the square, while the other dancers move into the middle if they are not already there.

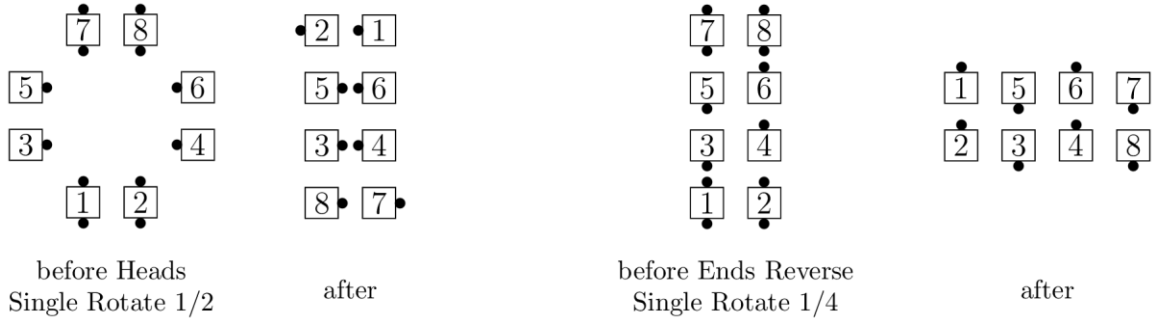

**Scatter Scoot / Scatter Scoot Chain Thru**

**Scatter Scoot**

From Parallel Waves: Leads All Eight Circulate while the others Scoot Back.



**Scatter Scoot Chain Thru**

From Waves only: The Leads All Eight Circulate while the Trailers Scoot Chain Thru.

**Scoot and Little / Little**

**Little**

From a 1/4 Tag or 3/4 Tag: Outsides 1/4 Right, or as directed, and then Counter Rotate 1/4. Centers Step and Fold. Ends in Parallel Waves or Lines. The quartering direction for the outsides may be specified, as in "Left Little" or "Right Little" (outsides go left or right, respectively).

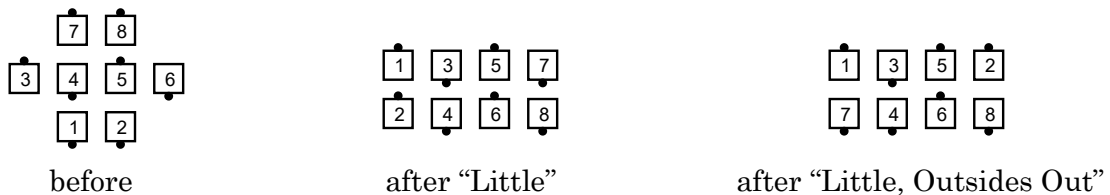

From Diamonds, there are many ways to direct the points to Counter Rotate without turning first, including: “Little, Points go as you are”, “Little, Points go forward”, and “Centers Start, Little”. (See Glossary of Modifying Terms: Start.) The command “Little” (with no direction given) requires the Points to 1/4 Right before they Counter Rotate. See the historical note below.

Consider the following two cases:

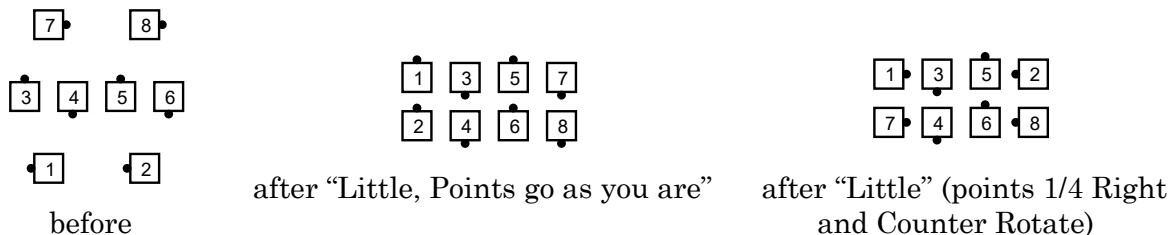

Historical note: In a previous definition Diamonds were a special exception because, without any words by the caller, the points would automatically go forward. Today the caller must direct the points to go “as you are”.

### Scout and Little

From a 1/4 Tag: Scout Back, then Little or Left Little, according to the hand with which the Scout Back was done, or outsides go as directed (as in “Scout and Little, Out on the outside”).

Scout and Little diagrams at right:

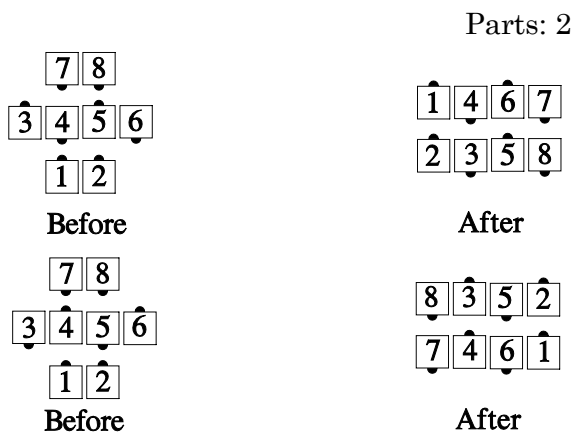

### Left Scout and Little

From a Left-Hand 1/4 Tag only: (This usage is to be avoided, except when helping the dancers. This call is no different from Scout and Little from this formation.) Scout Back, then Left Little. The outsides always go to the left.

### Scout and Plenty / Plenty

#### Plenty

From a 1/4 Tag or 3/4 Tag:

- (1) Little
- (2) Split Circulate 2 (formerly called “Turn the Star 1/2”)
- (3) Ends Counter Rotate 1/4 and Roll while the Centers 1/2 Zoom to form a Wave

Ends in a 1/4 Tag.

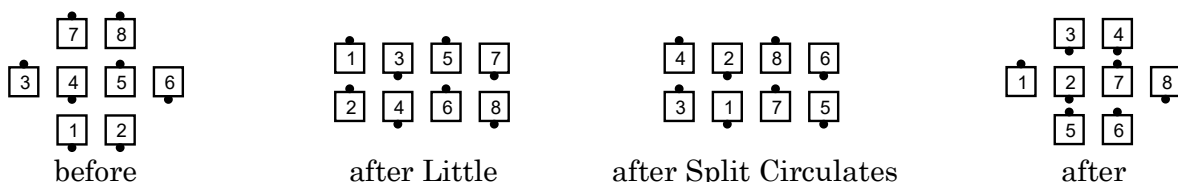

Notes: The caller can vary the number of Split Circulates (for example, “Plenty, do 3 Split Circulates”. If the caller wants to replace the Split Circulates with a different call, they should name the replaced part explicitly (for example, “Plenty, Replace the Split Circulates with ...”).

From Diamonds, if you want the points to go as they are, the proper usage is “Plenty, Points go as you are”. The command “Plenty” would start with the points doing a 1/4 Right.

Since the first part is a Little, the outside dancers normally begin with a Quarter Right but the caller can tell them to quarter in a different direction (for example, “Plenty, Outsides Face In”, “Left Plenty” (the Outsides quarter left), “Right Plenty” (the outsides quarter right).

### **Scoot and Plenty**

Parts: 4

From a 1/4 Tag: Scoot Back, then Right Plenty or Left Plenty, depending on the hand with which the Scoot Back was done. The outsides can also take a direction, as in “Scoot and Plenty, Outsides Out.”

Note: This call is defined to have 4 parts: the Scoot Back and the 3 parts of Right Plenty or Left Plenty.

### **Left Scoot and Plenty**

Parts: 4

From a Left-Hand Quarter Tag only: (This usage is to be avoided, except when helping the dancers. This call is no different from “Scoot and Plenty” from this formation.) Scoot Back, then Left Plenty. The outsides always go to the left.

Notes: Traditional usage says that on a Plenty the outsides go to the Right. This makes sense because they shouldn't be responsible for the handedness of the Wave behind them.

Traditional usage has the outsides on a “Scoot and Plenty” from a Left-Hand Quarter Tag go to the left. This makes sense because it is one call and the dancers just used the left hand on the Scoot Back, so they should automatically continue to the left after the Scoot Back.

From a Left-Hand 1/4 Tag, the command “Scoot Back and Plenty” is two calls, and the outsides should go to the right even though “Scoot and Plenty” would have them go to the left. It is unfortunate that these two similar-sounding phrases have a different dance action. Callers should avoid trying to trick dancers in this way.

On a “Left 3/4 Tag and Plenty”, the outside dancers go to the right. Use “Left 3/4 Tag and Left Plenty” to have the outside dancers go to the left.

On a “Scoot Chain Thru and Plenty” from a Left-Hand 1/4 Tag, the outside dancers go to the right. Use “Scoot Chain Thru and Left Plenty” to have the outside dancers go to the left.

**Scoot and Ramble / Ramble**

**Ramble**

From a 1/4 or 3/4 Tag: The Outsides separate and Slide Thru with each other, while the Centers Single Wheel and Slide Thru.

Parts: 2

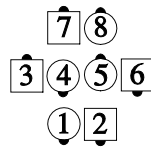

Before

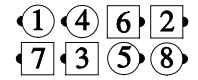

After

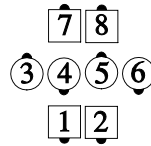

Before



After

**Scoot and Ramble**

From 1/4 Tag: Scoot Back, then Ramble.

Note: This call is defined to have 3 parts: the Scoot Back and the 2 parts of Ramble.

Parts: 3

**Shakedown**

From a 2x2 formation with everyone as Leaders only: As one continuous move, Quarter Right, Box Counter Rotate 1/4, and Roll. This call cannot be fractionalized.

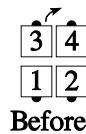

Before

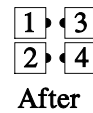

After

**Siamese Concept**

From a formation composed of two Tandems and two Couples: Same as “In Tandem or As Couples”: Those who are in the Tandems work in Tandem, and those in the Couples work As Couples, and everyone does the 2-dancer or 4-dancer call specified.

**Spin the Windmill variation**

**<anything> the Windmill**

From any appropriate formation: The Centers (or everyone, if the call is an 8-person call) do the <anything> call. Then the Centers Cast Off 3/4 while the Ends face as directed and Circulate twice (or as directed). For example, “Mix the Windmill In”.

**Split Square Thru variations**

These calls start from appropriate T-Bone Boxes (each box consists of a trailing Couple and two Facing Dancers) or a Static Square. The action always begins with “those facing Right Pull By and Quarter In” (to face those who didn’t pull by). From a Static Square, the caller will designate the couples (heads or sides) who will move into the center and perform the part of the facing dancers.

Comment: Using the helper word “Start” can cause confusion with the “Start” modifier. Here are proper call examples:

- From a Static Square, call “Heads Split Dixie Diamond”;
- From T-Bone Boxes, call “Split Dixie Diamond”.

**Split Square Chain the Top**

From an appropriate T-Bone Box: Those facing right Pull By and Quarter In; all Left Spin the Top; all Left Turn Thru. Ends in Back-to-Back Couples.

**Split Dixie Style to a Wave**

Parts: 2

From an appropriate T-Bone Box: Those facing Right Pull By and Quarter In; all Left Touch a Quarter. Ends in a Left-Hand Box.

**Split Dixie Diamond**

Parts: 2

From appropriate T-Bone Boxes: Split Dixie Style to a Wave; the Centers Hinge while the Ends U-Turn Back (turning toward each other). From a T-Bone formation with Centers facing each other and Ends facing in as a Couple, Split Dixie Diamond ends in Right-Hand Twin Diamonds.

**Split Dixie Sashay**

Parts: 2

From appropriate T-Bone Boxes: Split Dixie Style to a Wave; Slither. Ends in Parallel Left-Hand Two-Faced Lines. (Dancers should anticipate the Slither action and blend smoothly into it from the Left Touch a Quarter action that concludes Split Dixie Style to a Wave.)

**Square Chain the Top**

From Facing Couples: Right Pull By and Quarter In; Left Spin the Top; Left Turn Thru. Ends in Back-to-Back Couples.

**Square the Bases**

Parts: 3

From Facing Lines:

- (1) Centers Square Thru 3 while the Ends Pass Thru and Ends Bend
- (2) Split Square Thru 2
- (3) Trade By

Ends in an Eight Chain Thru formation.

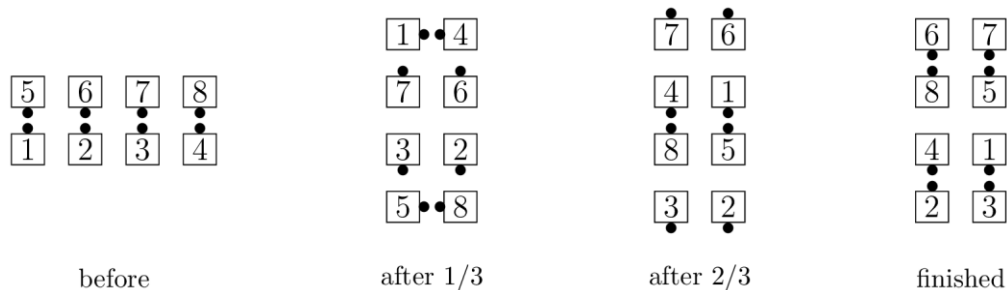

**Square the Bases But <anything>**

Callers have historically used “Square the Bases But <anything>” in a variety of ways, including replacing the Centers’ final part, replacing the Split Square Thru 2, or replacing the Split Square Thru 2 and the Trade By. With the adoption of the general “But” modifier in 2023 (page 16), callers are expected to use “Square the Bases But <anything>” only to replace the Centers’ final

part (Pass Thru). Callers should use other terminology for other replacements, such as “Square the Bases, Replace the Split Square Thru 2 with <anything>.” Callers may also refer to the numbered parts; for example, “Square the Bases, Replace the second part with <anything>,” or “Square the Bases, Replace the last two parts with <anything>.”

### Squeeze Family

#### **Squeeze**

From two dancers side-by-side, either directly adjacent or separated: If the dancers are adjacent, they Trade and slide apart; if they are separated, they slide together and Trade. When this call is given to multiple pairs of dancers whose paths cross (such as in a Diamond), the adjacent dancers move first.

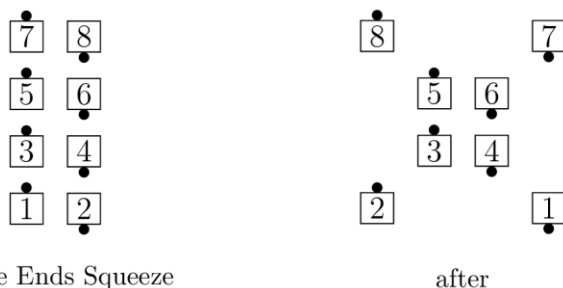

#### **Squeeze the Galaxy / Hourglass**

From a Galaxy / Hourglass: The three pairs of dancers who are all facing the same set of walls (head walls or side walls) Squeeze; the other two dancers do not move. A Galaxy becomes an Hourglass, and vice versa.

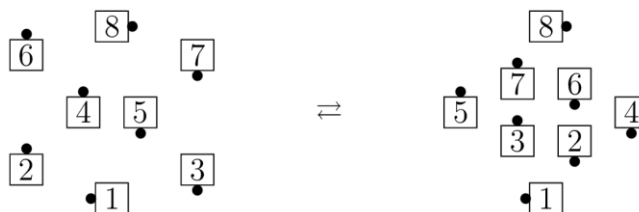

#### **Squeeze the Butterfly / O**

From a Butterfly / O: All Squeeze. A Butterfly becomes an O, and vice versa.

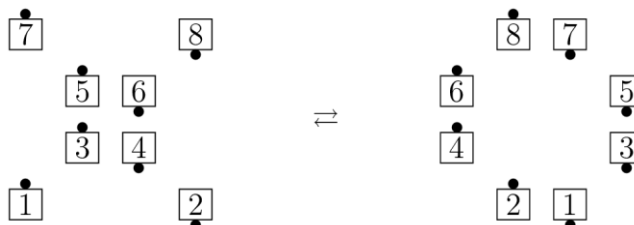

### Squeeze the Diamond

From a Diamond: The Centers Squeeze and the Points Squeeze. Because of the crossing paths, the Centers move first.



When Squeeze the Diamond is directed to 8 dancers, Twin Diamonds become Point-to-Point Diamonds, and vice versa.

### Step and Flip

From a General Line: The Centers step forward as the Ends Run. A Line with Centers facing the same direction ends in a Box (2x2); a Line with Centers facing opposite directions ends in a "Z" (2x3).

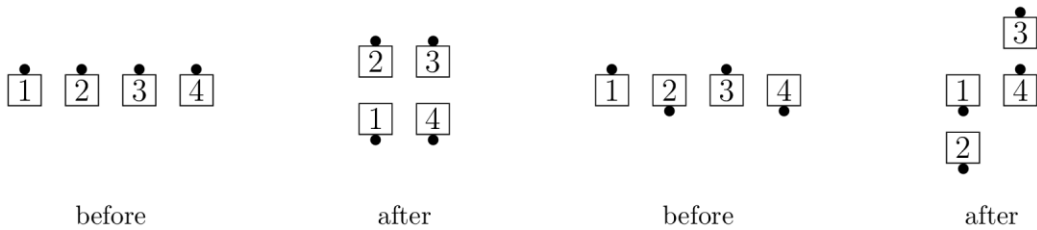

If the overall starting formation is a Tidal Line, the Centers of each side take a full step forward and the original Ends from each side finish lined up with the original Ends from the other side.

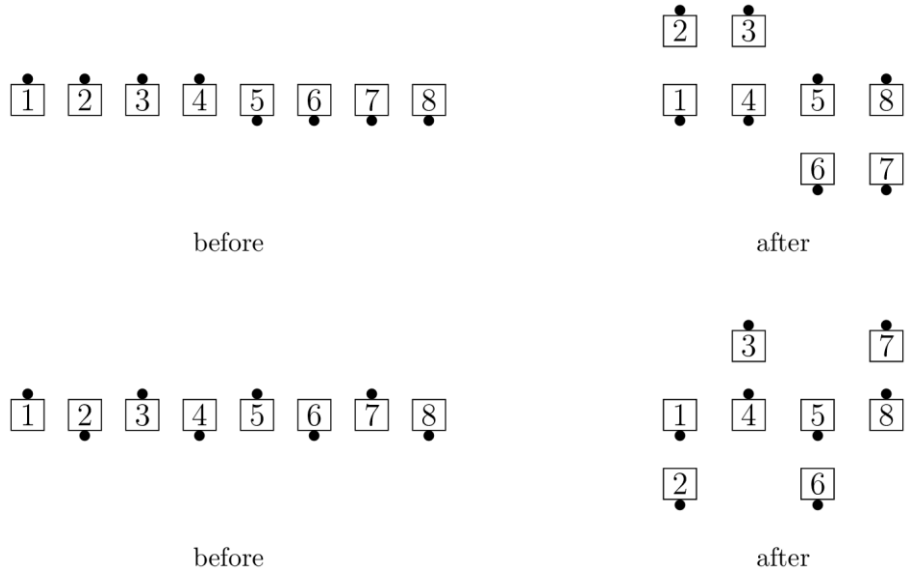

If the overall starting formation is a (2×4), each Line works independently and finishes in a Box (2×2) or Z (2×3) on each side.

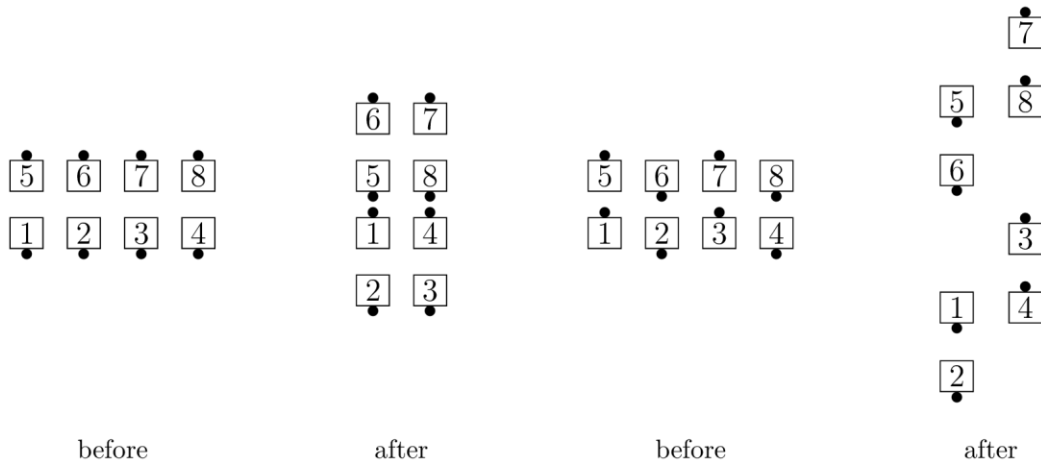

**Step and Fold**

From an Inverted Line, a Wave, or a Right-Hand or Left-Hand Diamond only: The Centers step forward and the Ends Fold to end in a Box Circulate formation, Tandem Couples, or T-Bone Box.

Examples of Step and Fold:

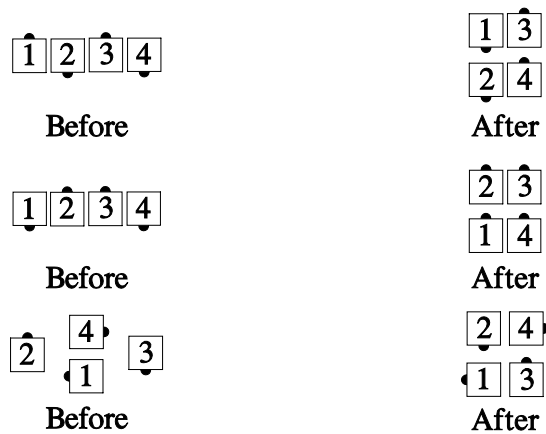

**Step and Squeeze**

From a General Line: The Centers step forward as the Ends Squeeze. A Line with Centers facing the same direction ends in a Box (2×2); a Line with Centers facing opposite directions ends in a “Z” (2×3).

Note: This call always ends in the same general formation (2×2, 2×3 (Z), 3×4, or others) as Step and Flip, when used with the same facing directions. See the diagrams in Step and Flip for examples. For Step and Squeeze, those who Squeeze will also have gone past each other (#1 goes past #4, #5 goes past #8).

**Stretch Concept**

From all appropriate formations: The modifier “Stretch” is used as a prefix, applied to two- or four-person calls only. Do the 2- or 4-person call as usual, but the people who end in the center move to the center spots farthest from the dancers they had been working with (by moving along the long axis of the formation).

Stretch Recycle:



Stretch Shakedown:



Stretch Turn and Deal:



Stretch Touch a Quarter:



Stretch Touch:

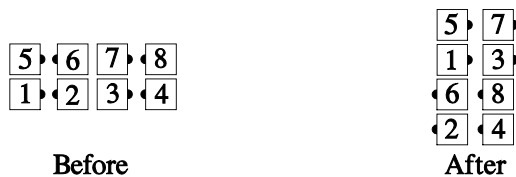

If the Centers cannot move along the long axis of the formation to get away from the Ends they had been working with, then the call is improper.

For example, “Stretch Swing Thru” is not proper from here:

because after the Swing Thru, the centers would have to move along the short axis of the formation to get away from the ends.

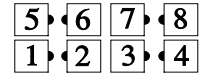

Similarly, one may not call “Centers Stretch Touch a Quarter” from here:

because the Centers weren’t working with the Ends on the Touch a Quarter.

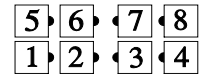

Note: The examples above are here only to clarify the definition. They do not necessarily represent good usage—particularly “Stretch Turn and Deal” from Left-Hand Two-Faced Lines.

Common applications include “Recycle”, “Ah So”, and “Turn and Deal” (from Right-Hand Two-Faced Lines).

*Teaching Hint:* This call is usually danced with those coming to the center actually going to the far center spots, rather than first completing the move on their own side.

### Substitute

From Tandem Couples: Lead Couple makes an arch and backs up while the Trailing Couple moves forward ducking under the arch. No one changes facing direction. Ends in Tandem Couples.

Other formations are possible and the caller is responsible for making it obvious which dancers are to arch. Usually, they are active or designated. Depending on the facing directions of those making the arch, they may move forward or backwards. Those going under the arch may move forward, backwards, or even sideways. Examples:

- From a Trade By formation, “Centers Arch and Substitute Over the Ends”.
- From a Squared Set, “Heads Touch a Quarter and Substitute (Over the Sides)”.
- From a Galaxy, “Centers Substitute Over One”.
- From a Galaxy, “Those in the Wave-Based Triangle, Substitute”.

### Swing and Circle (1/4, 1/2, 3/4, Full)

Each 1/4 is considered a part From a 1/4 Tag, 3/4 Tag, a Wave between Parallel Mini-Waves, or Diamonds (but not Facing Diamonds): The dancers in the Wave Swing. The Very Center dancers Trade while the Outer Six move one position, in the direction shown in the diagrams below (that is, as determined by the Ends of the Wave), turning as necessary to end in a 1/4 Tag. This completes Swing and Circle 1/4.

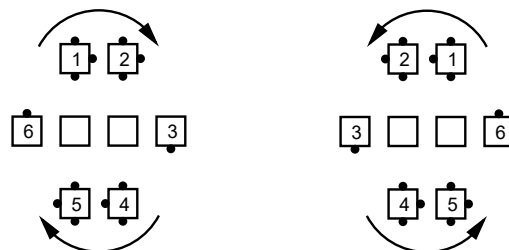

Repeat the entire above action, as necessary:

- once more, for Swing and Circle 1/2
- twice more, for Swing and Circle 3/4
- three more times, for a full Swing and Circle

The Facing Couples Rule applies to the Centers.

Swing and Circle 1/4:

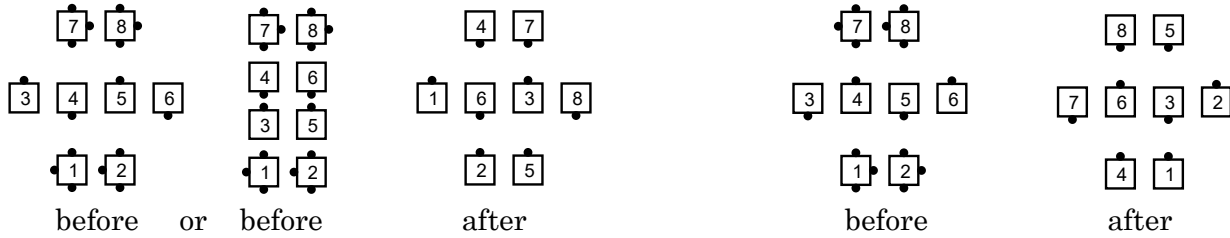

Note: Dancers who end in the Outer Six can Roll if their facing direction changed in the final part of the call. For example, “Swing and Circle 1/4 and Roll”:

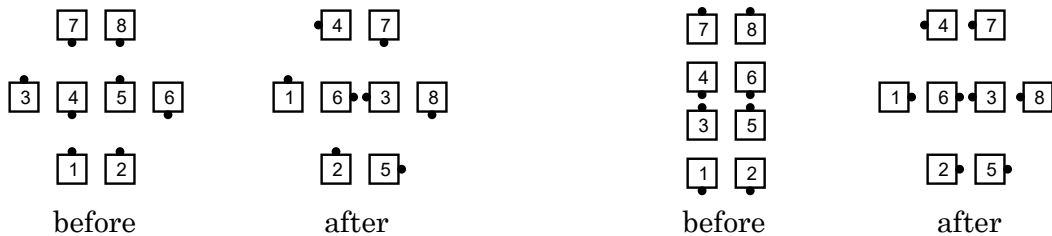

**Swing the Fractions**

Parts: 5

From Parallel Waves, or other appropriate formations: Those who can Turn 1/4 by the Right, those who can Turn 1/2 by the Left, those who can Turn 3/4 by the Right, those who can Turn 1/2 by the Left, and those who can Turn 1/4 by the Right. For example,

from Right-Hand Waves:

or from Left-Hand Waves:

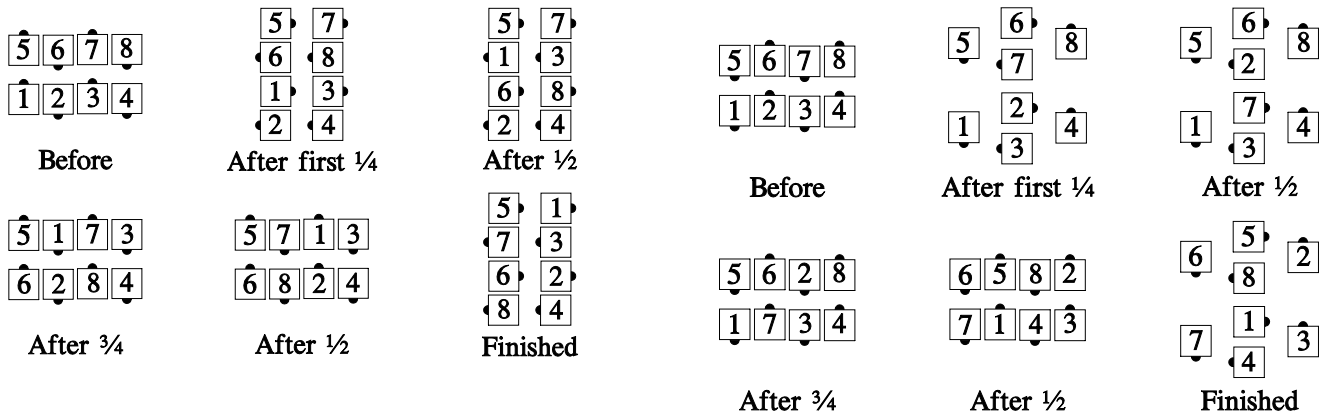

For each part of the call, there must be a dancer performing both this part and the immediately preceding or following one. For example, the call is not proper from Magic Columns.

This is a 5-part call, with each arm turn being one part. “Swing the Fractions 4/5” is common.

**Switch the Line**

From a General Line: Centers Run, while the Ends Cross Run. In cases where dancers would collide, those doing the Cross Run move outside of those doing the Run; otherwise, all the usual shoulder passing rules apply.

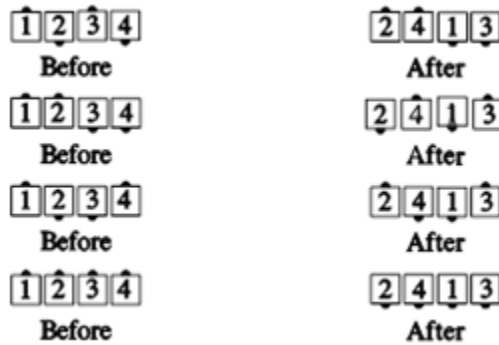

**Switch to an Interlocked Diamond**

From Parallel Waves or Lines: Centers Run, while the Ends do their part of Interlocked Diamond Circulate.

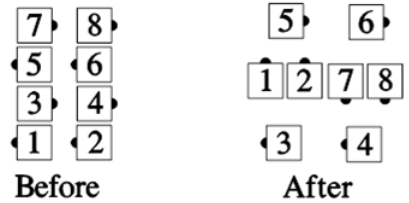

**T-Bone Formation**

"T-Bone" (or "T-Boned") describes any formation that contains two adjacent dancers whose facing directions are perpendicular.

For example:

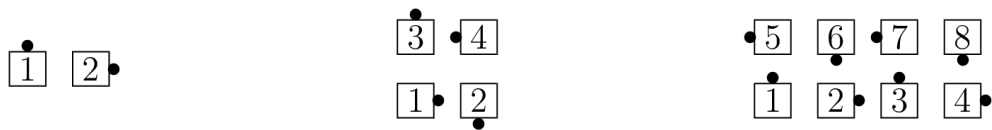

T-Bone Pair

T-Bone Box

T-Bone 2x4

Many other examples are possible, including different sets of facing directions and different overall formations (such as T-Bone 1x4, T-Bone 1x8).

To dance a call from a T-Bone formation, each dancer does their part of the call as they would from a non-T-Bone formation of the same shape. However, the ending formation may be different.

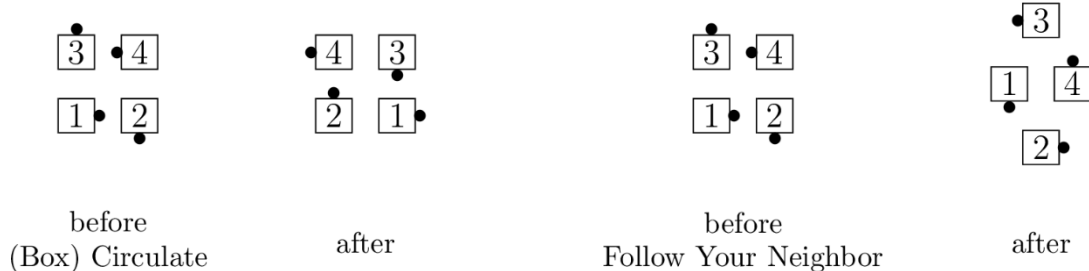

As shown in the call names above, the caller will usually just give the call name and not actually say “T-Bone”. “T-Bone” is simply a formation description, not the name of a concept or part of a call name. “T-Bone” may be used as part of a cue, such as “You’re T-boned”, and dancers are expected to know what this means.

In a T-Bone 2x4, some dancers are in General Lines and others are in General Columns. To do a call from these formations, some dancers find it helpful to explicitly think about being in Lines or Columns.

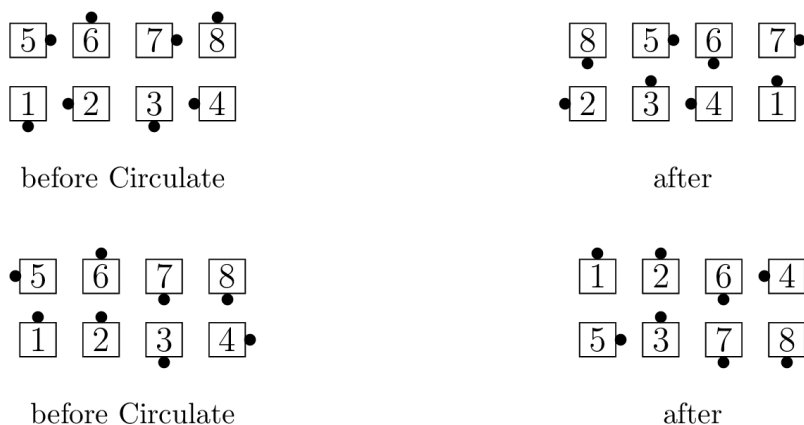

The call “1/2 Circulate” can be difficult from a T-Bone setup. Dancers going “around the corner” for their Circulate path must carefully walk in an arc around those walking straight ahead to ensure taking the correct hands with the dancers they meet. This is not an instance of the Same Position Rule.

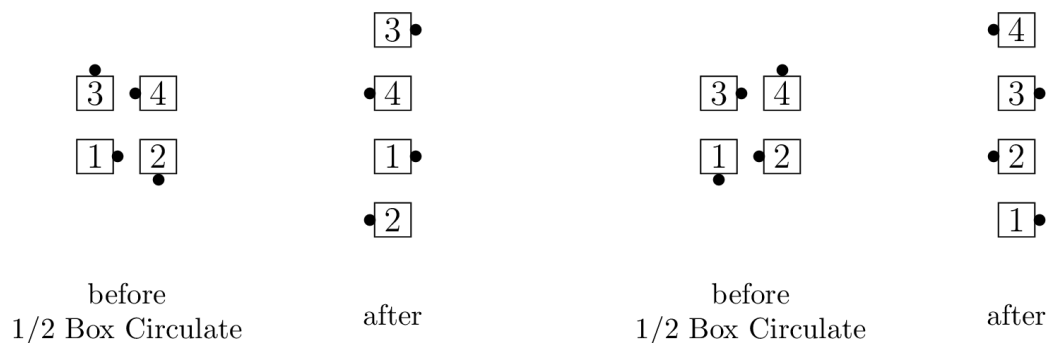



The requirement that *adjacent* dancers have perpendicular facing directions avoids labeling typical Triangles, Diamonds, Hourglasses, and Galaxies as T-Boned. A Triangle, for example, is only considered T-Boned if its base is T-Boned. However, many formations on a large grid, such as a 4×4 or 2×6, are considered T-boned if any two dancers, not necessarily adjacent, have perpendicular facing directions. See “Butterfly and O Concepts” for specific examples.

### <Tag> Back Family

Parts: 2

“<Tag>” indicates a short name for a “tagging call”, that is, a call similar to Tag the Line in that it has a 1/2 Tag position, a 3/4 Tag position, and so on. Three tagging calls are part of the C-1 program; their names are:

- “Tag” for Tag the Line
- “Flip” for Flip the Line
- “Vertical Tag” (no shorter name)

All calls in the <Tag> Back family have 2 parts:

- (1) Do the tagging call to the 1/2 Tag position.
- (2) Scoot Back.

### Flip Back

From a Wave: Flip the Line 1/2; Scoot Back. Ends in a Box Circulate formation.



### Tag Back

From a Line or Wave: 1/2 Tag; Scoot Back. Ends in Box Circulate formation.

### Vertical Tag Back

From a Box of Four that is not T-Boned: Vertical 1/2 Tag; Scoot Back. Ends in Box Circulate formation.

Historical Note: The calls (Vertical) Tag Back were previously named (Vertical) Tag Back to a Wave. The names were shortened in 2024 to reduce confusion with the “<anything> To a Wave” modifier and to make these names consistent with the other call in this family, Flip Back.

**Tally Ho**

Parts: 3

Parallel Waves or Lines, Trade-By, and 2x4 T-Bones: All 1/2 Circulate. The centers Hinge and 1/2 Box Circulate, while the outsides Trade. Those who meet Cast 3/4 while the other four dancers Hourglass Circulate, to form Parallel Waves or Lines.

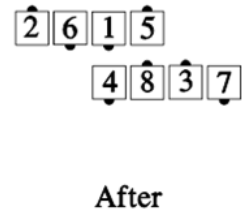
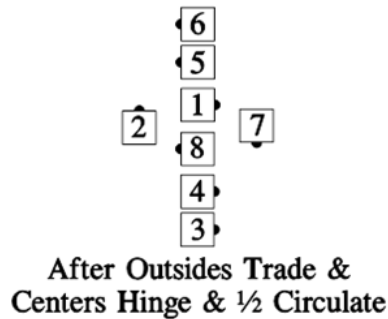
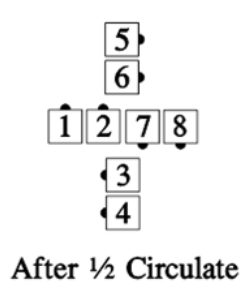
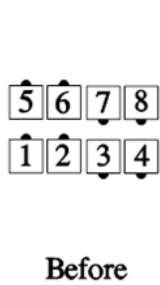
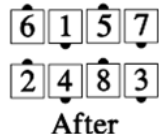

In the second example the dancers doing the Hourglass Circulate come to the same spot and take right hands.

**Tandem Concept**

Similar to the “As Couples” concept, but the two dancers that work as a unit are a Tandem. Nobody ever comes between the dancers in a Tandem.

For example, “Tandem Swing Thru”:

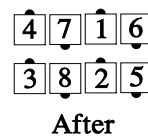
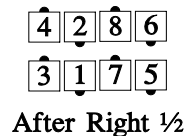
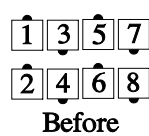

or “Tandem Quarter Thru”:

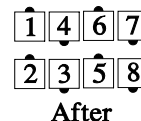
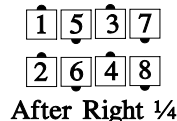
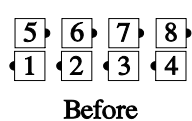

Common applications include Touch a Quarter, Hinge, Scoot Back, Swing Thru, Walk and Dodge.

### 3 by 2 Acey Deucey

From anywhere there are two groups of three that can Triangle Circulate, and a center two that can Trade (for example, Twin Diamonds, or an Hourglass): The Very Center Two dancers Trade while the two Triangles Circulate.



### Track (0, 1, 2, 3, 4)

From a Completed Double Pass Thru only: As one smooth motion, Tandem Partner Trade and then Extend the given number of times. This call cannot be fractionalized.

- Track 0 ends in a Double Pass Thru;
- Track 1 ends in a Right-Hand 1/4 Tag;
- Track 2 ends in Right-Hand Waves (this is the same as the Plus call of the same name);
- Track 3 ends in a Right-Hand 3/4 Tag;
- Track 4 ends in a Completed Double Pass Thru.

### Triangle Formation / Triangle Circulate

#### **Triangle Formation**

A Triangle is a formation of 3 dancers. One is the apex and the other two form the base. The apex dancer must be the same distance from each of the base dancers. If the base dancers are aligned in a General Column, the triangle is called a Tandem-Based Triangle. If the base dancers are aligned in a General Line, the triangle is called a Wave-Based Triangle. In some triangles all 3 dancers may not be adjacent to each other. Triangles are found as parts of a Galaxy, Hourglass, Twin Diamonds and various other formations.

#### **Triangle Circulate**

From a Triangle: Each dancer moves forward one position along one of the circulate paths shown below:



*Teaching Hint:* Every dancer has one shoulder toward the inside of the Triangle. After Triangle Circulate, that same shoulder is still toward the center.

Note: On Triangle Circulate from a T-Bone Triangle (base dancers are T-Boned to each other), base dancers use their own starting position to determine whether to treat the Triangle as Tandem-Based or Wave-Based, whereas Apex dancers use the starting position of the spot to which they Circulate.

**Inside / Outside Triangles**

Various formations, including Twin Diamonds and Point-to-Point Diamonds, contain Triangles.

**Inside Triangle:** The Center 6 form the Triangles.

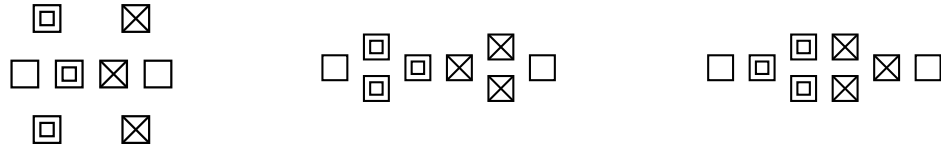

**Outside Triangle:** The Outside 6 form the Triangles.



**Inpoint / Outpoint Triangles**

The footprints of Twin Diamonds, with the outside 4 in Tandem, contain additional Triangles. Each of these triangles has one point as the apex and two of the center 4 as the base.

**Inpoint Triangle:** Each point facing in is an Apex.



**Outpoint Triangle:** Each point facing out is an Apex.



**Tandem-Based / Wave-Based Triangles**

Various formations, especially a Galaxy, contain triangles that may be identified by the formation of their “base”. A Wave-Based Triangle has the dancers in the base usually in a Mini-Wave (also possible: a Couple). A Tandem-Based Triangle has the dancers in the base usually in a Tandem (also possible: Facing or Back-to-Back dancers).

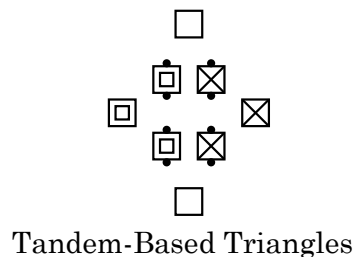
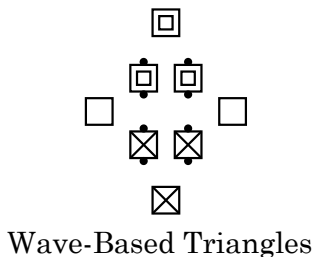

Examples of various Triangle Circulates:

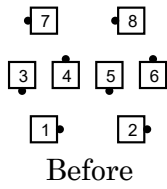

Before

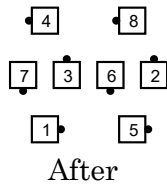

After

Outpoint Triangle Circulate

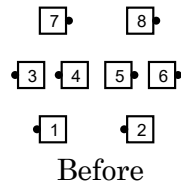

Before

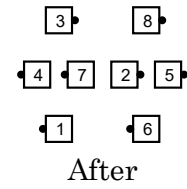

After

Inpoint Triangle Circulate

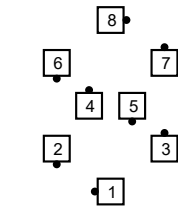

Before

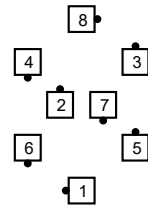

After

Tandem-Based Triangle Circulate

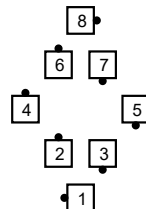

Before

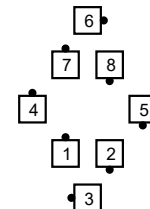

After

Wave-Based Triangle Circulate

**Triple Box / Column / Line / Wave Concept**

This concept establishes three groups of 4 dancers each; the dancers in each group are in either a Box, Column, Line, or Wave. Since there are 12 spots and only 8 actual dancers, 4 of the spots will be vacant (occupied by phantom dancers). Calls are executed by working with your group of 4.

Examples of the spots and who works with whom:

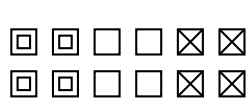

Triple Boxes

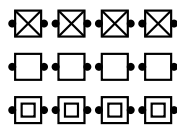

Triple Columns (parallel)

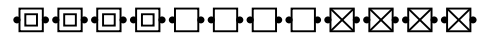

Triple Columns (end-to-end)

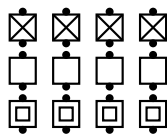

Triple Lines or Waves (parallel)

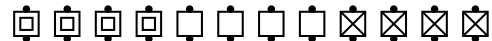

Triple Lines or Waves (end-to-end)

Examples of Triple Box / Column / Line / Wave usage:

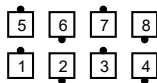

before

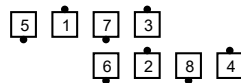

after

Triple Box Circulate

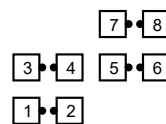

before



after

Triple Column, Pass and Roll

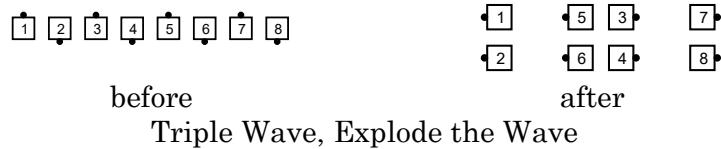

Common Triple Box calls are Circulate, Counter Rotate, Right and Left Thru, Scoot Back, Shakedown, Touch a Quarter, Walk and Dodge, and Wheel Thru.

Common Triple Wave or Line calls are Swing Thru, Mix, and Switch the Wave.

Common Triple Column calls are Pass and Roll, Touch a Quarter, and Dixie Style to a Wave.

When using this concept to execute a call, the “set” is the group of four dancers. Dancers execute all calls as if only these four dancers are on the floor. For example, in “Triple Box Pass In”, dancers Pass Thru and then turn to face the center of their Triple Box.

**Twist the Line / Twist and <anything>**

**Twist the Line**

From a Line, centers facing the same way, and genders arranged appropriately: The Centers step forward and Partner Trade while the Ends Face, move in, and Star Thru. This is a gender-dependent call (because of the Star Thru).

**Twist and <anything>**

From a Line, centers facing the same way: The Centers step forward and Partner Trade while the Ends Face, move in, and do the <anything> call—which will involve only the original Ends unless otherwise specified. For example,

Twist and Square Thru 2:

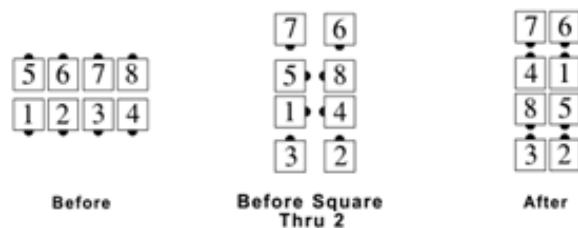

Twist and Split Square Thru 2:

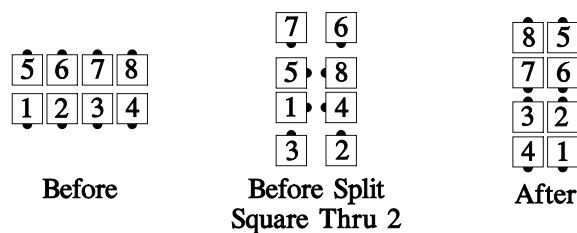

Twist and Pass Out:

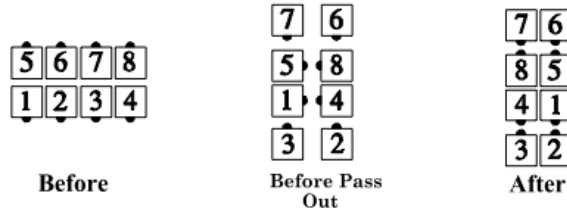

Twist and Nothing:



**Vertical Tag (1/4, 1/2, 3/4, Full)**

From a Box of Four that is not T-Boned:

- Dancers in a Trailing Couple have the Belle step in front of the Beau, forming a Tandem
- Dancers in a Leading Couple Single Wheel
- Dancers in a Mini-Wave have the Leads Fold

After the appropriate beginning, dancers continue in one smooth motion to finish a Tag the Line (that is, walk forward for as many tag positions as indicated). This call cannot be fractionalized.

Vertical Tag:



Vertical 1/2 Tag:

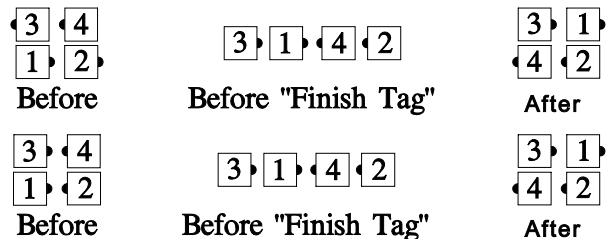

**<anything> to a Wave**

From wherever is appropriate for the <anything> call: The <anything> call must have as its final action a Step Thru or Extend. Do the <anything> call, except for the final Step Thru or Extend.

For example, in “Square Chain Thru to a Wave”, the dancers would do all of the call except for stepping forward on the final Left Turn Thru:

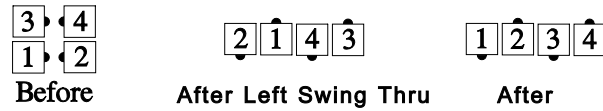

Square Thru 3 to a Wave:



Additional applications include Scoot Chain Thru to a Wave, Load the Boat Centers to a Wave, Percolate Outsides to a Wave, or Flip Back to a Wave.

Callers wanting to use this modifier with (Vertical) Tag Back should use additional words for clarity, such as “Tag Back, Centers to a Wave”. This avoids confusion with the old call names (Vertical) Tag Back to a Wave. See the Historical Note in the definition of <Tag> Back.

Do not be confused by calls which contain “to a Wave” as part of their name (for example, “Single Circle to a Wave”, “Right Roll to a Wave”, “Cross Roll to a Wave”).

**Weave**

From Box Circulate: The Leads do 1/2 a Box Circulate while the Trailers walk forward on a slight diagonal to meet each other with their original outside hands (thought of by some as Cross Extend) and Hinge.

From Single Eight Chain Thru: All Pass Thru, and the Ends Quarter Right while the Centers Left Touch a Quarter (this is like Touch and Weave).



**Wheel and <anything>**

From any formation in which exactly two Couples are facing directly away from the center of the set with no one in front of them: The Couples facing out Promenade 1/4, ending facing in, while the other dancers move into the center (if necessary) and do the <anything> call.

**Reverse Wheel and <anything>**

From any formation in which exactly two Couples are facing directly away from the center of the set with no one in front of them: The Couples facing out Wrong Way Promenade 1/4, ending facing in, while the other dancers move into the center (if necessary) and do the <anything> call.

**Wheel and Touch a Quarter:**

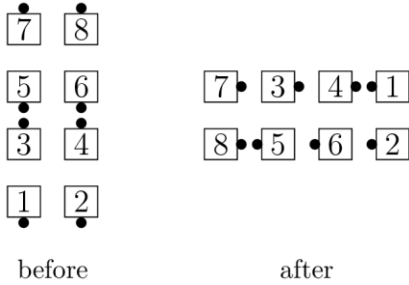

**Reverse Wheel and Right Roll to a Wave:**

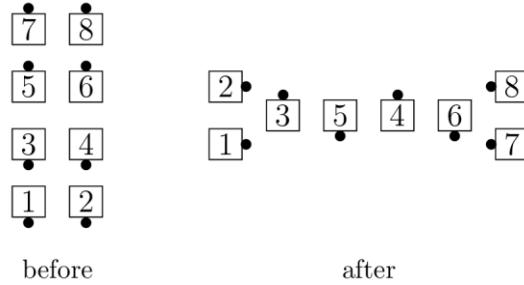

**Wheel and Pass the Ocean:**

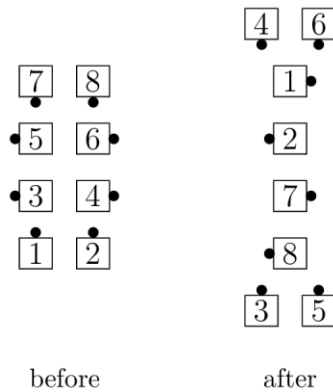

**Reverse Wheel and Spin the Top:**

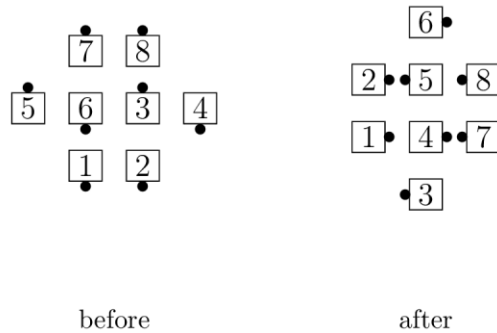

**Wheel Fan Thru**

From Facing Couples: Start a Wheel Thru, but as the Beaus meet, they Trade (by the right) and then all complete the Wheel Thru.



**With the Flow**

From Facing Couples, with each couple having sideways body flow—as a couple—resulting from the previous call or with exactly one dancer in each couple moving forward: This is a flowing Walk and Dodge. The leading dancer in flow direction walks forward, as the other dancer dodges into the space being vacated.

**Zing**

From a Box Circulate or Tandem Couples: Leaders Zoom but only turn 3/4 (270 degrees) as they go (similar to Quarter Out and Run). Trailers Circulate and Quarter In. Zing is also proper from various 3-and-1 Boxes, T-Bone Boxes, and from an isolated Tandem.

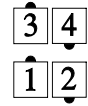

Before



After



Before



After

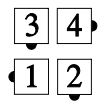

Before

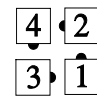

After

Points Zing:

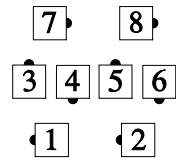

Before

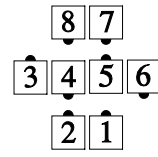

After

## History of Document Changes

Date	Change
04/23/2003	Added <b>Press In/Out/Right/Left/Ahead</b> . Corrected graphic for <b>Switch the Line</b> . Removed <b>Grand Follow Your Neighbor</b> . Removed INDEX section.
01/16/2004	Updated <b>Recycle, Percolate, (Anything) to a Wave</b> , and <b>Press</b> (to <b>Press Ahead</b> only). Added <b>Substitute</b> .
03/01/2004	Added comment about <b>(Anything) and Spread</b> ; Update <b>Cross Your Neighbor, Relay the Top, Scoot &amp; Plenty/(Anything) &amp; Plenty, (Anything) and Weave</b> , and <b>Zing</b> .
10/22/2004	Updated <b>Shakedown</b> and <b>Substitute</b> . Added <b>Cross Extend</b> .
11/19/2005	Several minor editorial changes.
01/12/2006	Corrected typos, definitions and diagrams <b>(Anything) to a Wave, Concentric Concept, Switch to a Diamond, Switch to an Hourglass, Chain Reaction</b> , and <b>Make Magic</b> .
03/11/2006	Revised <b>Swing the Fractions</b> . Several editorial changes.
08/10/2006	Added diagram for <b>Twist &amp; Split Square Thru 2</b> . Several editorial changes. Add diagrams to <b>Chain Reaction</b> and <b>Alter the Wave</b> .
08/13/2006	Corrected “preformed” to “Performed” in <b>Interrupt</b> .
10/12/2006	Reformatted document from two columns to one column.
08/27/2007	Changed comments about <b>Flip Back, Tag Back to a Wave</b> , and <b>Vertical Tag Back to a Wave</b> .
12/07/2007	Minor edits to various diagrams.
06/01/2008	Added <b>Triple Waves/Lines Concept</b> (from C-2).
12/01/2008	Added missing diagram to <b>Twist and (Anything)</b> .
12/09/2009	Converted to Word, minor edits and formatting changes, updated <b>Triple Box, Line, Wave</b> , add <b>Triple Column</b> .
01/04/2010	Updated copyright; Minor edits to <b>Right-Shoulder Rule, Partner, Replace, But #1, But #2, Delete, do your part, Alter the Wave, Beaus and Belles Naming Convention, Other Butterfly calls</b> , such as <b>Split Circulate, Walk and Dodge, Concentric Concept, (Anything) Chain Thru, O Formation/Concept, Other O calls, Rotate, Swing and Circle, Swing the Fractions, Wheel Fan Thru, Left Wheel Fan Thru</b> , and <b>Zing</b> .
02/08/2010	Minor edit to <b>Start</b> and <b>Replace</b> . Delete <b>(Anything) and Little, (Anything) and Plenty, (Anything) and Ramble, Left Shakedown, Left Swing the Fractions</b> , and <b>Left Wheel Fan Thru</b> . Added <b>With the Flow</b> (from C-2). Removed restriction in <b>Press Ahead</b> . Revised <b>(Anything) Chain Thru*, Interlocked Diamond Circulate*</b> , and <b>Triangle Formation / Triangle Circulate*</b> . Added diagrams to <b>Interlocked Diamond Formation</b> . Replace diagrams in <b>Triangle Circulate</b> .
02/12/2010	Removed restriction in <b>Stretch Concept</b> . Added common applications to the following Concepts: <b>Concentric, O, Phantom, Stretch, Tandem, Triple Box/Line/Wave/Column</b> . Minor edit to <b>Magic Columns</b> . Added example to <b>(Anything) the Windmill</b> . Add another example to <b>T-Bone Formation</b> . Redraw <b>Flip Back</b> diagrams.
02/20/2010	Added “This page intentionally left blank”. Update <b>O Formation/Concept*</b> . Added diagrams for <b>Wave-Based Triangle Circulate</b> and <b>Interlocked Diamond Circulate</b> .

<b>Date</b>	<b>Change</b>
05/26/2010	Minor update to <b>Other O calls</b> . Updated <b>Triangle Formation</b> . Calls marked with an asterisk on 2/8/10 and 2/20/10 were all approved on 5/26/10. Edited them to remove the note that they have yet to be approved.
11/12/2010	Revised <b>Swing and Circle 1/4, 1/2, 3/4, Full</b> .
12/02/2010	Converted to Word on PC. Added missing diagram for <b>Swing and Circle</b> .
12/11/2010	Underlined call names.
05/13/2011	Revised <b>Wheel and (Anything)</b> .
12/06/2011	Changed Diagrams for <b>Plenty</b> .
12/20/2011	Changed Definition for <b>Little</b> .
08/06/2012	Updated diagram label in <b>Vertical Tag (1/4, 1/2, 3/4, Full)</b> .
01/05/2013	<b>Cross and Turn</b> , removed restriction of U-Turn Back towards partner.
01/07/2016	Removed <b>Triple Cross</b> ; add <b>Cut and Flip the Galaxy</b> .
05/04/2016	Added 1/4 Tag usage of <b>Cross Your Neighbor</b> .
10/31/2016	Added <b>Cross Over Circulate</b> to “How Calls Are Extended at C-1” preface.
03/09/2017	Revised <b>Triple Box/Column/Line/Wave Concept</b> to define <b>Triple Box Pass In</b> .
01/05/2018	Updated copyright to 2018; update <b>Triangle Formation / Triangle Circulate</b> and added <b>Split Counter Rotate</b> to the preface.
09/03/2018	Removed <b>Beaus and Belles Naming Convention</b> (now in the Advanced Definitions). Update <b>Ocean Wave Rule</b> list of calls.
12/10/2018	Updated index to include <b>Scoot and Plenty/Plenty</b> .
11/28/2021	Added <b>Track (0, 1, 2, 3, 4)</b> . Revised <b>Dixie Diamond</b> and <b>Dixie Sashay</b> . Revised <b>Split Square Thru Variations</b> and added <b>Split Dixie Sashay</b> . Added <b>Pass and Roll Your Cross Neighbor</b> (pending). Revised Ocean Wave Rule list of calls. Revised <b>Touch, Left Touch</b> , and <b>Left Pass Thru</b> in Glossary. Revised <b>Left</b> and <b>Reverse</b> in Modifiers. Minor edits to <b>Cast Back, Cross By, Percolate, Rotate, Recycle variations, Step and Fold, Swing the Fractions, Tally Ho</b> , and <b>Vertical Tag</b> . Revised format and changed to angle brackets.
02/22/2022	Completed the pending definition of <b>Pass and Roll Your Cross Neighbor</b> . Revised <b>Concentric</b> .
08/18/2022	Revised <b>Squeeze</b> to create a family and improve the clarity. Revised <b>Wheel and &lt;anything&gt;</b> to permit additional starting formations.
12/09/2022	Revised the <b>Rotate Family</b> and <b>Regroup</b> to permit additional starting formations. Added Ends of Lines and Ends of Columns to <b>When the Formation Isn't There</b> . Minor edits to change “his” to “their”.
11/02/2023	Added <main call> <b>But &lt;anything&gt;</b> and removed <b>But</b> from the “Glossary of Modifying Terms”. Modified <b>Pass the Axle</b> and <b>Scoot and Plenty</b> in accordance with the new <b>But</b> definition. Revised the definition of <b>Square the Bases</b> to clearly have 3 parts and added <b>Square the Bases But &lt;anything&gt;</b> . Updated <b>Split Counter Rotate</b> in “How Calls Are Extended at C-1” due to a recent change in the Advanced Definitions.

<b>Date</b>	<b>Change</b>
08/30/2024	Revised <b>Chase Your Neighbor</b> . Added <b>Chase Your Cross Neighbor</b> . Revised <b>Step and Flip</b> . Added <b>Step and Squeeze</b> . Changed <any tagging call> <b>Back to a Wave</b> to the <Tag> <b>Back Family</b> . Adjusted <b>Vertical Tag</b> and <anything> <b>to a Wave</b> to match the names in the new <Tag> <b>Back Family</b> . Capitalized call names, formation names and dancer designators. Changed “setup” to “formation” where appropriate. Shortened some “Ocean Wave” references to “Wave”. Edited punctuation in <b>Alter the Wave</b> and <b>Pass the Axle</b> . Minor edits to <b>Flip the Line</b> .
11/18/2025	Added <b>Calls with Parts</b> and more information about C-1 calls with parts. Removed redundant information about <b>Cast a Shadow</b> .
02/19/2026	Revised <b>Butterfly and O Concepts</b> , <b>T-Bone Formation</b> , and <b>Concentric Concept</b> .
03/01/2026	In the section How Calls are Used at C-1, revised <anything> and <b>Spread</b> to match the new Plus definition.